

**SECTION 500:
PAVEMENT CONSTRUCTION STANDARDS**

<u>Page No.</u>	<u>Description</u>
500-2	501 GENERAL
500-2	501.1 STANDARD DOCUMENTS
500-2	501.2 PROTECTION OF RIGHT-OF-WAY IMPROVEMENTS
500-2	501.3 PRIVATE STREETS
500-3	501.4 PAVING RESTRICTIONS
500-3	501.5 MAINTENANCE OF TRAFFIC
500-3	501.6 UTILITY IDENTIFICATION
500-3	501.7 SIDEWALK CLOSURES IN THE CENTRAL BUSINESS DISTRICT
500-4	501.8 FINAL ACCEPTANCE
500-4	501.9 AMERICANS WITH DISABILITIES ACT
500-5	502 MATERIALS
500-5	502.1 SUBGRADE
500-5	502.2 SUBBASE
500-5	502.3 BITUMINOUS CONCRETE PAVEMENT
500-5	502.4 PORTLAND CEMENT CONCRETE PAVEMENT
500-6	503 CONSTRUCTION
500-6	503.1 SUBGRADE
500-7	503.2 SUBBASE
500-7	503.3 BITUMINOUS CONCRETE PAVEMENT
500-7	503.4 PORTLAND CEMENT CONCRETE PAVEMENT
500-7	503.5 PAVEMENT MARKINGS
500-7	503.6 PAVEMENT PROTECTION AND REPAIR
500-8	504 INSPECTION AND TESTING
500-8	504.1 GENERAL REQUIREMENTS
500-8	504.2 LABORATORY QUALIFICATIONS
500-9	504.3 TESTING REQUIREMENTS
500-9	504.4 PAVEMENT EVALUATION
500-12	590 STANDARD DETAILS

501 GENERAL

The standards and requirements found in this article are for materials and construction of roadway pavement, parking lots, driveways, and bicycle/pedestrian pavement within the City of Naperville, Illinois.

501.1 STANDARD DOCUMENTS

The following list of Standard Construction Documents define the methods, materials, and testing to be utilized when designing and constructing transportation improvements. The sections in this specification are intended to define further particular elements of both design and construction of transportation projects in Naperville, Illinois. The City Engineer shall decide all questions that arise as to the interpretation of the specifications.

- a) Design Manual, latest edition (IDOT)
- b) Construction Manual, latest edition (IDOT)
- c) Soils Manual, latest edition (IDOT)
- d) Highway Standards, latest edition (IDOT)
- e) Manual of instructions for Concrete Proportioning and Testing, latest edition (IDOT)
- f) Manual of Instructions for Bituminous Proportioning and Testing, latest edition (IDOT)
- g) City of Naperville, Concrete Construction in the Public Right-of-Way

501.2 PROTECTION OF RIGHT-OF-WAY IMPROVEMENTS

The developer and contractor shall have the responsibility to adequately protect the pavement and property, curb and gutter and other right-of-way improvements, whether newly constructed or existing, from any and all damage. Sufficient means shall be employed by the contractor to protect against such damage to the satisfaction of the City Engineer.

Any new or existing improvements that are damaged shall be repaired or replaced in a manner that is satisfactory to the City Engineer.

The contractor and/or developer shall secure all necessary rights to perform any work on private property not within the ownership rights of the developer. The developer shall bear the sole responsibility for damages that may occur as a result of work performed under contracts they initiate.

501.3 PRIVATE STREETS

Private streets shall be designed and constructed in accordance with the standards set forth for public streets.

501.4 PAVING RESTRICTIONS

Roadway construction shall only be permitted between April 15 and November 15, weather permitting, unless otherwise authorized in writing by the City Engineer. This authorization will in no manner void the obligation of the developer and contractor to adhere to the specifications or guarantee the work.

501.5 MAINTENANCE OF TRAFFIC

The contractor shall employ the appropriate methods of traffic control in accordance with the plans, specifications and the Manual on Uniform Traffic Control Devices, such that the safety of vehicles, and pedestrians is preserved at all times. The erection and maintenance of the traffic control devices shall be to the satisfaction of the agency of jurisdiction and the City Engineer.

501.6 UTILITY IDENTIFICATION

When newly poured curbs are installed, the contractor shall use a City approved stamp to indent the wet concrete with an "S" to identify the location of each sanitary manhole and sewer stub and/or indent the wet concrete with a "W" to identify the location of each water valve or water service. The letters shall be indented at the top of the curb and shall be one and one-half (1 1/2) inches to two (2) inches in height, one and one-half (1 1/2) inches to two (2) inches in width, embedded at least three-eighths (3/8) inch deep.

If the developer and/or the contractor fail to indent the curbs as outlined above, the City will require that identification medallions or other symbols as approved by the City Engineer be affixed to the curb.

501.7 SIDEWALK CLOSURES IN THE CENTRAL BUSINESS DISTRICT

Closure of sidewalk in the Central Business District poses a serious impediment to access by the heavy pedestrian volume of residents and business employees. Sidewalks shall not be closed unless approved by the City Engineer; any sidewalk closures will be granted only for the brief periods of time needed and shall not be for an entire project. Closure of a sidewalk will be granted by the City Engineer only for those phases of a construction project for which there are no acceptable safe methods of keeping the sidewalk open to pedestrian travel. The following requirements apply to all approved sidewalk closures:

- a) Temporary sidewalks shall be used around or through closed off areas rather than closure of a sidewalk whenever possible. Temporary sidewalks shall comply with ADA standards.
- b) For any closure of a sidewalk, a pedestrian guide signing plan shall be developed as part of the permit submittal. The pedestrian guide signing plan will include directional signing to adjacent municipal parking lots and directional signing to existing designated pedestrian crosswalks at all-way stop and traffic signal controlled intersections, as well as the sidewalk closure signs incorporated into the IDOT standards. The pedestrian guide signing plan shall comply with ADA standards. The project may not commence until the pedestrian guide and closure signing is in place.

- c) Overhead and lateral pedestrian protection shall be installed, where necessary, to insure pedestrian safety, as directed by the City Engineer based upon a review of the project and its sequence of work.
- d) Mid-block pedestrian crosswalks shall not be allowed on Chicago Avenue or on Washington Street due to the high volume of traffic and the multiple traffic lanes of these roads.
- e) Mid-block pedestrian crosswalks for locations other than those noted above may be granted as part of the pedestrian work zone plan by the City Engineer based upon the submittal of a pedestrian traffic engineering study. Appropriate warning signs (and flashers) are required for mid-block pedestrian crossings.
- f) Closure of a sidewalk shall be by a portable or permanent fencing as directed by the City Engineer. Barricades and warning tape are not to be used. Short term closures (those less than 5 days) may be done with barricades and warning tape.

501.8 FINAL ACCEPTANCE

The developer shall maintain the integrity of the pavement, provide periodic cleaning of the pavement, and perform snow removal until final acceptance of the roadway.

All newly constructed bituminous concrete surface courses shall have the curb line joints routed and sealed with rubberized sealant conforming to ASTM 3405. The routed reservoir shall be 0.5 inches by 0.5 inches square.

All newly constructed bituminous concrete surface courses shall be treated with an approved preservative rejuvenating agent, applied at a rate of 0.05 gal per sq yd.

501.9 AMERICANS WITH DISABILITIES ACT

All pedestrian facilities shall be constructed in accordance with the latest requirements of the Americans with Disabilities Act (ADA). It is the Contractor's responsibility to review the site conditions and the design plans prior to construction to verify that the proposed improvements can be constructed per ADA requirements. In the event that the proposed improvements cannot be constructed per the ADA requirements, the designer should be consulted and appropriate action must be taken. Appropriate action may include a field change, a plan revision, or a memo to the City from the designer indicating why a certain aspect of the ADA cannot or will not be met. The City will not accept any improvements that fail to meet the requirements of the ADA without documentation from the designer.

It is recommended that the Naperville Standard Details be consulted when designing and constructing pedestrian improvements. However, all improvements must ultimately be in accordance with the 2010 ADA Standards for Accessible Design published by the Department of Justice and the Illinois Accessibility Code published by the Illinois Capital Development Board.

502 MATERIALS

502.1 SUBGRADE

All subgrade material shall have a minimum Illinois Bearing Ratio (IBR) of 3.0 as measured by a dynamic cone penetrometer. Subgrade material having an IBR of less than 3.0 shall be modified by undercutting and backfilling the unsuitable areas in accordance with Section 503.1.

502.2 SUBBASE

Unless otherwise indicated, all subbase shall be constructed of compacted, crushed aggregate meeting IDOT gradation CA-6.

502.3 BITUMINOUS CONCRETE PAVEMENT

Bituminous concrete base course, bituminous concrete binder course and bituminous concrete surface course shall meet the mix design and gradation for the State of Illinois specifications for Bituminous Aggregate Mixture, Bituminous Concrete Binder Course Class modified, and Bituminous Concrete Surface Course Class I modified, respectively. All mix designs shall be approved by the City Engineer. The surface course on all original roadway construction and pavement widenings shall be comprised of only virgin materials.

502.4 PORTLAND CEMENT CONCRETE PAVEMENT

The pavement shall be of Portland cement concrete with or without reinforcement constructed on a prepared subgrade and subbase.

502.4.1 ADMIXTURES

No admixtures other than air entrainment agents in accordance with ASTM C-33 shall be used in the concrete without prior written approval of the City Engineer. All admixtures shall meet all applicable AASHTO and ASTM standards and requirements. The use of calcium chloride is not allowed unless approved in writing by the City Engineer and then only when added by the concrete supplier at the batch plant in accordance with the IDOT Manual of Instructions for Concrete Proportioning and Testing.

502.4.2 SIDEWALKS & DRIVEWAYS

All sidewalks and commercial driveway approaches shall be constructed of Class PV concrete (6.1 bags of cement) with an air entrainment of 6-8% at a maximum slump of 4 inches. Residential driveway aprons and service walks may be constructed of materials other than Portland cement concrete or bituminous concrete provided that the design is approved by the Transportation, Engineering and Development Business Group and a permit is obtained for the work. As a condition of the permit, a covenant running with the land must be recorded subjecting the property to covenants and restrictions concerning the alternate driveway surface or service walk.

502.4.3 CURING AND PROTECTION

If membrane curing compounds are utilized they shall also be a type which provides a protective seal which is satisfactory to the City Engineer.

503 CONSTRUCTION

503.1 SUBGRADE

The subbase material shall be laterally supported by a sufficient amount of initial backfill material to prevent movement of the subbase during placement of the concrete and/or removal of the form work.

503.1.1 UNSUITABLE SOILS

Any subgrade material deemed unsuitable by the City Engineer shall be removed and replaced with granular material. The depth of undercut shall be based on the existing subgrade material and strength and shall be approved by the City Engineer. All subgrade sections undercut and backfilled shall be drained with underdrain pipe connected to a new or existing storm sewer or drainage system. Underdrain pipe shall be PVC schedule 40 or SDR 35 with factory drilled perforations, with a minimum diameter of 4 inches.

503.1.2 LIME MODIFICATION

Modification of soils by the use of lime requires prior approval by the City Engineer. Lime modification will only be allowed as a means to expedite construction in those instances where the moisture levels of the subgrade soils prevent construction by standard methods in a time frame deemed acceptable to the City Engineer. Lime modification shall be done in accordance with Section 302 of the Standard Specifications for Road and Bridge Construction, except as modified herein.

The developer or his engineer shall provide a minimum of 10 pounds (5 kg) of lime and 100 pounds (45 kg) of on-site soil, located in the proposed subgrades to be modified, prior to construction of the lime modified subgrade. The lime shall be proportioned within a range of 2% to 6% of soil (oven-dry basis). The required proportion of lime shall be established by the developer's engineer or geotechnical consultant prior to construction, using samples of the proposed soil and lime and IDOT's laboratory procedure for lime modified soil.

The mix design and documentation of all the tests necessary to calculate the mix design shall be submitted to the City Engineer at least 5 days prior to the construction of the lime modified soils. The developer's engineer or geotechnical consultant does have the right to make such adjustments of lime proportioning as considered necessary during the progress of the work, within the range specified (2% to 6%). The source or type of lime shall not be changed during the progress of the work without permission of the City Engineer, and after additional documentation and soil testing.

Upon completion of the lime modified subgrade the developer's engineer or geotechnical consultant shall provide documentation of field tests certifying that the required standard dry density has been obtained. Upon receipt of the documentation the City Engineer shall allow the developer to schedule and perform a proof roll of the subgrade. All areas that fail the proof roll shall be repaired until the subgrade meets the proof roll requirements.

503.2 SUBBASE

A stabilized subbase shall be constructed in accordance with Article 312 of the IDOT Standard Specifications, except that pozzolanic stabilized mixtures are not permitted.

503.3 BITUMINOUS CONCRETE PAVEMENT

Bituminous concrete pavement shall be constructed in accordance with Article 403 through Article 408 of the IDOT Standard Specifications.

503.4 PORTLAND CEMENT CONCRETE PAVEMENT

503.4.1 CURB & GUTTER

All concrete curb and gutter shall be constructed in accordance with Naperville Standard Details 590.20 through 590.24 as appropriate, and Section 1020 of the IDOT Standard Specifications.

Where curb and gutter crosses utility trenches, the curb and gutter shall be constructed with two No. 4 epoxy coated deformed steel reinforcement bars extending a minimum of 3 feet beyond the edges of the trench.

503.4.2 COMMERCIAL DRIVEWAY APRONS

All driveway aprons or approaches shall be constructed in accordance with Naperville Standard Details 590.5, 590.6 and 590.7, and Section 1020 of the IDOT Standard Specifications.

503.4.3 SIDEWALK

All sidewalks shall be constructed in accordance with Naperville Standard Details 590.30, 590.31, and 590.32, and Section 1020 of the IDOT Standard Specifications.

503.4.4 CURING AND PROTECTION

All concrete curb and gutter, sidewalk and other concrete pavements in the City of Naperville shall be cured in accordance with the IDOT Standard Specifications. All provisions of Section 1020.13 shall be employed. All membrane products shall be applied in accordance with the manufacturer's recommendations.

503.5 PAVEMENT MARKINGS

All pavement markings and markers shall be installed in accordance with Article 780 through Article 783 of the IDOT Standard Specifications.

503.6 PAVEMENT PROTECTION AND REPAIR

The contractor shall be responsible to adequately protect all pavement within the public right-of-way. The City Engineer shall have the sole authority in determining if the pavement has been damaged. Upon the request of the City Engineer, the contractor shall remove the damaged sections of pavement at no cost to the city. Any damaged curb and gutter shall be replaced by a new segment of no less than five feet in length.

504 INSPECTION AND TESTING

During the construction of any public roadways within the corporate limits of the City of Naperville, testing shall be performed in accordance with the requirements of this section.

In accordance with the Naperville Municipal Code, all sidewalk contractors must be licensed and the contractor must request an inspection by the Department of Transportation and Engineering for all work within the public right-of-way.

504.1 GENERAL REQUIREMENTS

The project owner will employ and pay for the services of a qualified independent testing laboratory to provide the materials testing, as specified, in conjunction with the owner's project engineer and the City Engineer.

Following the completion of the testing and the preparation of the applicable reports, copies shall be distributed as follows:

- a) One copy to the project owner
- b) One copy to the owner's project engineer
- c) One copy to the City Engineer
- d) One copy to the contractor

Failure to provide the applicable test reports will impede adjustments to bonds, letters of credit, the execution of further work and acceptance of the improvements or the issuance of occupancy permits.

504.2 LABORATORY QUALIFICATIONS

The materials testing consultant and laboratory shall meet the general requirements of the ASTM E-329 "Standards of Recommended Practice for Inspection and Testing Agencies for Concrete, Steel and Bituminous Materials used in Construction".

The materials testing consultant shall provide qualified personnel promptly upon notice and shall cooperate with the owner's project engineer, the City Engineer or representative and the contractor. Any irregularities or deficiencies in the work observed during the performance of services shall be promptly reported to the owner, the owner's project engineer and the City Engineer. The contractor shall cooperate with the materials testing consultant by providing sufficient notice in advance of operations to allow assignment of personnel and scheduling tests, provide access to the work and manufacturing facilities, and provide representative samples of the materials to be incorporated into the work.

504.3 TESTING REQUIREMENTS

Table 500-1 outlines the material and construction testing requirements for pavements constructed within the public right-of-way in the City of Naperville. The table defines the testing requirements based on the material to be incorporated into the work.

The testing frequencies outlined in Table 500-1 are the minimum required for verification of the work; additional testing may be required due to the unique nature of a particular project or to verify or examine further deficiencies or irregularities in the work. Both the owner's project engineer and the City engineer reserve the right to order additional testing. The cost of both the initial testing and any additional testing shall be paid for by the project owner. The contractor reserves the right to contract the services of an equally qualified independent testing laboratory, at their expense, to perform additional inspections, sampling and testing when the initial tests indicate that the work is not in accordance with the contract document and specifications. The City Engineer shall have the final authority to make decisions regarding the acceptability of the work.

504.4 PAVEMENT EVALUATION

The City engineer will evaluate pavement in the right-of-way prior to final acceptance. This evaluation shall be based on the test results required by these standards, and by visual inspection of the pavement surface.

Prior to the acceptance of a Portland cement concrete pavement or the installation of the bituminous concrete surface course on either a composite pavement with a Portland cement concrete base course, a bituminous base course or an aggregate base course, a Dynaflect Pavement Evaluation Program Report shall be performed. The program shall include the following general testing/pavement evaluation techniques:

- a) Environmental Study (frost cycle, drainage, etc.)
- b) Pavement Surface Evaluation
- c) Soil borings at approximately one location per mile
- d) Dynamic Pavement Deflection Analyses (Dynaflect machine or equal correlated with Benkelmen Beam or equal)

The cost of the pavement evaluation shall be paid for by the developer. The engineer's estimate and the public improvement letter of credit shall provide an amount sufficient to perform the pavement evaluation. The amount shall be retained until satisfactory completion of the evaluation, payment of the cost of the evaluation to the City by the developer, and City Council acceptance of the roadway.

Prior to construction of the surface course, a field inspection shall be performed of the curb and gutter, base course, and binder course and all failures and deficiencies of the pavement shall be repaired by the contractor to the satisfaction of the City Engineer.

**TABLE 500-1
MATERIAL TESTING
FOR SUBGRADE/EMBANKMENT**

TYPE OF TEST	FIELD SAMPLING FREQUENCY	REMARKS
SOIL BORINGS ASTM D1586-84	MIN. EVERY 1000' AT APPROX. CENTERLINE OF ROW & ONE PER CUL-DE-SAC ^{1,3}	
BEARING RATIO COMPUTATION (IBR B554)	ONE PER TYPE OF SOIL ^{1,3}	
STANDARD PROCTOR/SIEVE ANALYSIS ASTM D698-91	MIN. ONE TEST PER SOIL CLASSIFICATION ^{1,2,3}	THE CITY RESERVES THE RIGHT TO REQUIRE THE MODIFIED PROCTOR ASTM D1557-91 BY NUCLEAR DENSITY DEVICE
ATTERBERG LIMITS AASHTO T-89 & T-90/ASTM D4318-95		
IN-PLACE MOISTURE DENSITY ASTM D2922-96 (SUB-GRADE)	MIN. ONE TEST EVERY 500' AND ONE PER CUL-DE-SAC ^{2,3}	
IN-PLACE MOISTURE DENSITY ASTM D2922-96 (EMBANKMENT)	FOR EACH 500' OF FILL AREA, ONE TEST PER EACH 3' OF EM-BANKMENT HEIGHT & NOT LESS THAN ONE TEST PER INDIVIDUAL FILL AREA ^{2,3}	
GRAB SAMPLE ASTM D75-97	OCCASIONALLY ²	LAB EVALUATIONS AS NEEDED
STRING-LINE SUBGRADE	MIN. EVERY 100' WITH A TOLERANCE OF 1/2" +/- ⁴	
PROOF ROLL	MIN. ENTIRE ROAD, EACH LANE OF TRAVEL ⁴	A FULLY LOADED 50,000 LB GVW TANDEM AXLE (6 WHEELER)
1/ PRE CONSTRUCTION 2/ CONSTRUCTION 3/ DEVELOPER'S/OWNER'S TESTING FIRM (MUST MEET ASTM REQUIREMENT E-329) 4/ MUST BE WITNESSED BY CITY OF NAPERVILLE		

**TABLE 500-2
MATERIAL TESTING
FOR AGGREGATE BASE/SUB-BASE**

TYPE OF TEST	FIELD SAMPLING FREQUENCY	REMARKS
STANDARD PROCTOR/GRADATION ASTM D698-91 (AASHTO T99-74)	MIN. ONE TEST PER TYPE OF MATERIAL & PER SOURCE OF SUPPLY ^{1,2,3}	THE CITY RESERVES THE RIGHT TO REQUIRE THE MODIFIED PROCTOR ASTM D1557-91
IN-PLACE MOISTURE DENSITY ASTM D2992-96	MIN. EVERY 500' PER LIFT ^{2,3}	MATERIAL MUST COME FROM AN APPROVED SOURCE
GRAB SAMPLE D75-97	OCCASIONALLY ²	LAB EVALUATIONS AS NEEDED
STRING-LINE	MIN. EVERY 100' MAX, TOLERANCE OF 1/4" +/- ⁴	
PROOF ROLL	MIN. OF ENTIRE ROAD, EACH LANE OF TRAVEL ⁴	A FULLY LOADED 50,000 LB GVW TANDEM AXLE (6 WHEELER)
1/ PRE CONSTRUCTION 2/ CONSTRUCTION 3/ DEVELOPER'S/OWNER'S TESTING FIRM (MUST MEET ASTM REQUIREMENT E-329) 4/ MUST BE WITNESSED BY CITY OF NAPERVILLE		

**TABLE 500-3
MATERIAL TESTING
FOR CONCRETE PAVEMENT**

TYPE OF TEST	FIELD SAMPLING FREQUENCY	REMARKS
PLANT INSPECTION	REQUIRED WITH A MIN. OF 100 C.Y. PER DAY ^{2,3}	PAVEMENT ONLY
SLUMP (IN FIELD) AASHTO T119 ASTM C-143, C-192	MIN. ONE TEST PER 50 C.Y. ^{2,3} (MIN. 2 TESTS PER DAY)	
AIR ENTRAINMENT (IN FIELD) ASTM C-231 AASHTO T152	MIN. ONE TEST PER 50 C.Y. ^{2,3} (MIN. 2 TESTS PER DAY)	AS PER IDOT'S "CONC. PROPORTIONING AND MANUAL OF INSTRUCTIONS AND TESTING"
STRENGTH (AASHTO T22&T23) 6"x12" SPECIMANS MAY BE USED ASTM C-39, C-87- ROADWAYS	MIN. 4 CYLINDERS PER 100 C.Y. (BREAKS AT 3, 7 AND 14 DAYS WITH 4TH HELD IN RESERVE)	30" BEAMS MAY BE CAST INSTEAD OF CYLINDERS
STRENGTH (AASHTO T22&T23) 6"x12" SPECIMANS MAY BE USED ASTM C-39, C-87	MIN. 3 CYLINDERS PER 50 C.Y. (BREAKS @ 14 & 28 DAYS WITH 3RD CYLINDER IN RESERVE) ^{2,3}	30" BEAMS MAY BE CAST INSTEAD OF CYLINDERS
1/ PRE CONSTRUCTION 2/ CONSTRUCTION 3/ DEVELOPER'S/OWNER'S TESTING FIRM (MUST MEET ASTM REQUIREMENT E-329) 4/ MUST BE WITNESSED BY CITY OF NAPERVILLE		

**TABLE 500-4
MATERIAL TESTING
FOR ASPHALT PAVEMENT**

TYPE OF TEST	FIELD SAMPLING FREQUENCY	REMARKS
PLANT INSPECTION	REQUIRED WITH A MIN. OF 100 TONS PER DAY ^{2,3}	
IN-PLACE DENSITY ASTM D1559, AASHTO T209, AASHTO T245	MIN. OF EVERY 200' PER LANE PER LIFT, ONE PER CUL-DE-SAC ^{2,3}	BY NUCLEAR DENSITY DEVICE
DENSITY/THICKNESS ASTM D2726-96, AASHTO T164, ASTM D1856-95, AASHTO T170, ASTM D2041-95	2 CORES MIN. PER DAY (ONE CORE FULL TESTING WITH SECOND CORE STANDBY) ^{2,3}	
1/ PRE CONSTRUCTION 2/ CONSTRUCTION 3/ DEVELOPER'S/OWNER'S TESTING FIRM (MUST MEET ASTM REQUIREMENT E-329) 4/ MUST BE WITNESSED BY CITY OF NAPERVILLE		

590 STANDARD DETAILS

- 590.01 Standard Roadway Section (4 sheets)
- 590.02 Concentric Cul-de-sac
- 590.03 Eccentric Cul-de-sac
- 590.04 Typical Alley Section
- 590.05 Typical Commercial Driveway Detail
- 590.06 Typical Residential Driveway Detail (2 sheets)
- 590.07 Typical Right-in/Right-out Access

Pavement Sections

- 590.10 Typical Pavement Details
- 590.11 Butt Joint Detail
- 590.12 Utility Trench Paving Section (Rigid Pavements)
- 590.13 Utility Trench Paving Section (Flexible Pavements)
- 590.14 Downtown Streetscape Pavement Section (2 sheets)

Curb & Gutter

- 590.20 B6.12 Barrier Curb & Gutter
- 590.21 B6.12 Barrier Curb & Gutter at Curb Inlets
- 590.22 M3.12 Mountable Curb & Gutter
- 590.23 Type B Barrier Curb
- 590.24 Curb Replacement

Sidewalks & Trails

- 590.30 Sidewalk
- 590.31 Sidewalk Construction
- 590.32 Curb Ramps
- 590.33 Crosswalk
- 590.34 Covered Walkway
- 590.35 Accessible Parking Space Markings (3 sheets)
- 590.36 Multi-use Trail

590.99 COMMON NAMES

All standard details in this section may be referred to by a common name in associated construction documents. The common name shall be "PAVEMENT xx" where the xx is the section of the detail number to the right of the decimal point. For instance, *Detail #590.30 Sidewalk* may also be referred to as "PAVEMENT 30".

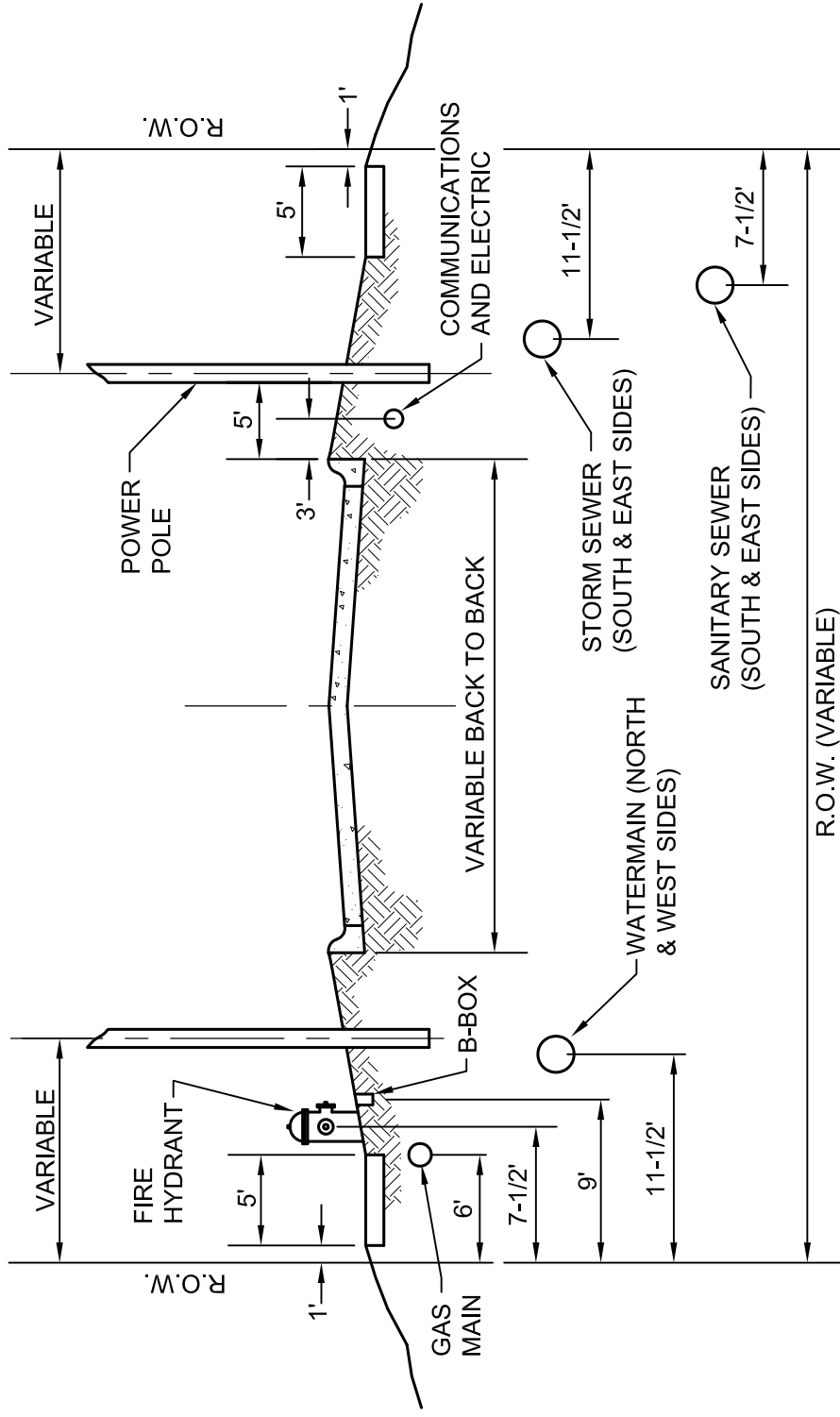

**STANDARD UTILITIES LOCATION
28' PAVEMENT WITHIN 66' R.O.W.**

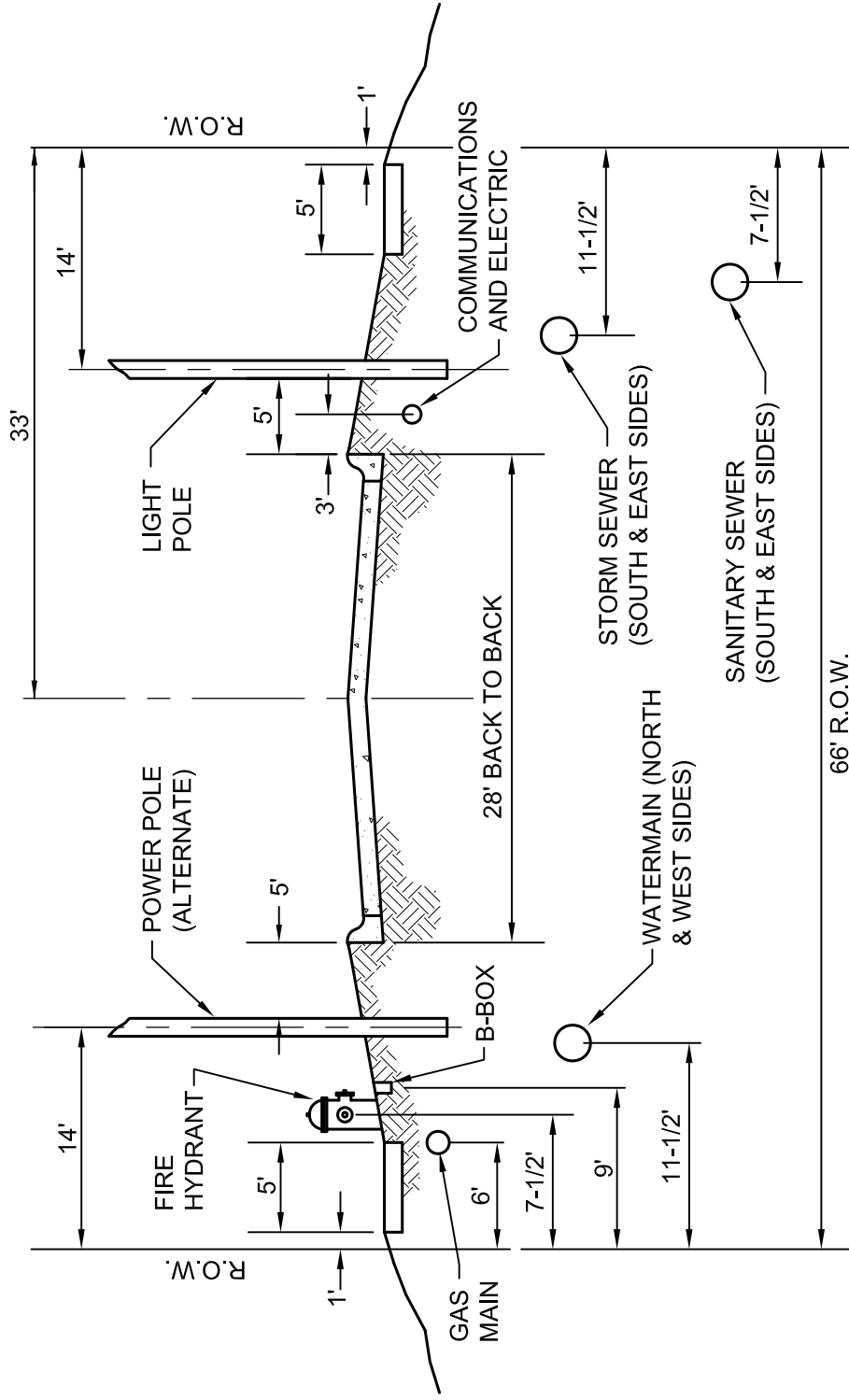

**STANDARD UTILITIES LOCATION
37' PAVEMENT WITHIN 80' R.O.W.**

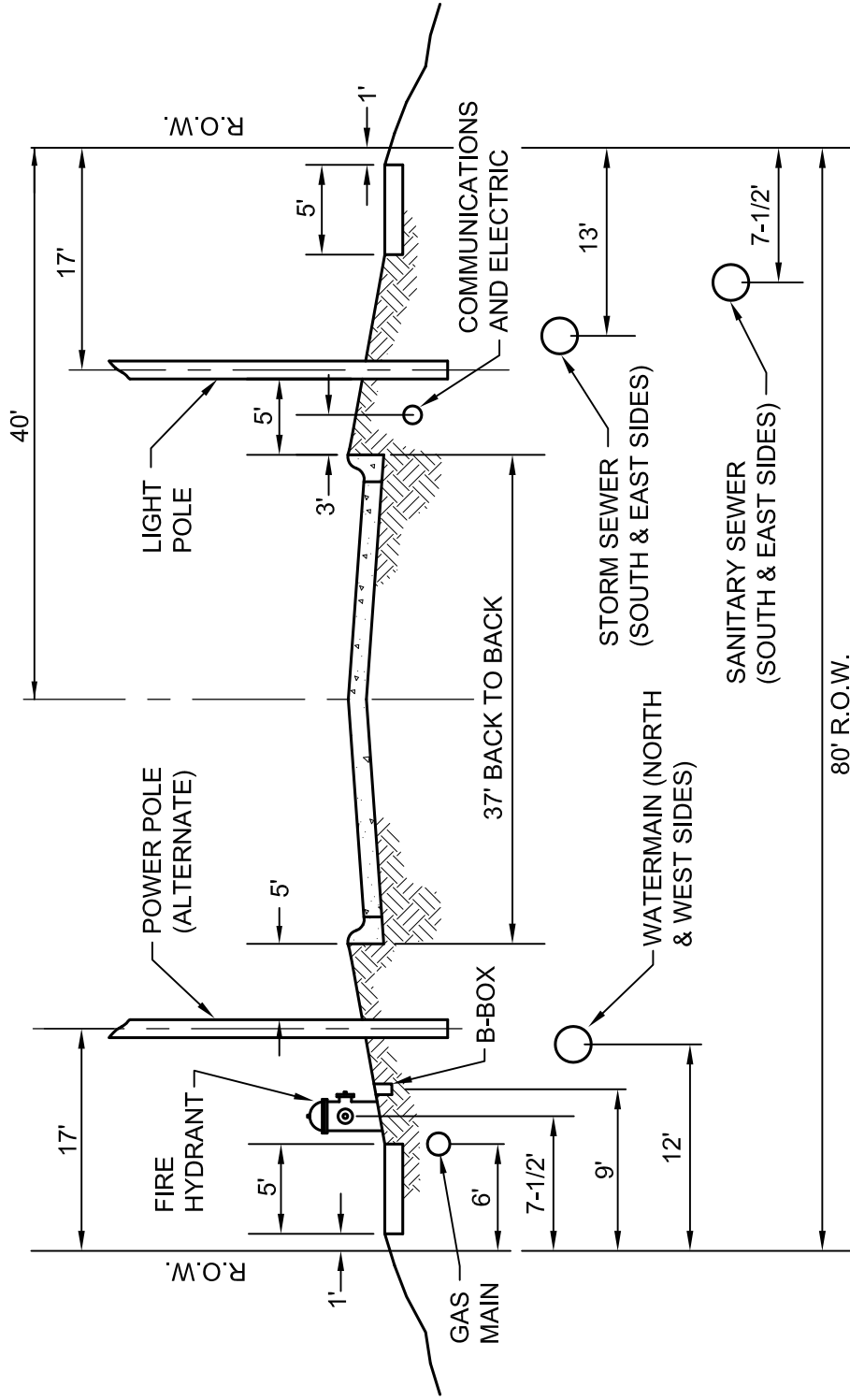

STANDARD UTILITIES LOCATION

4-12' LANES, LEFT TURN LANE AND MEDIAN NOT MORE THAN 17' WIDE WITHIN A 100' R.O.W.

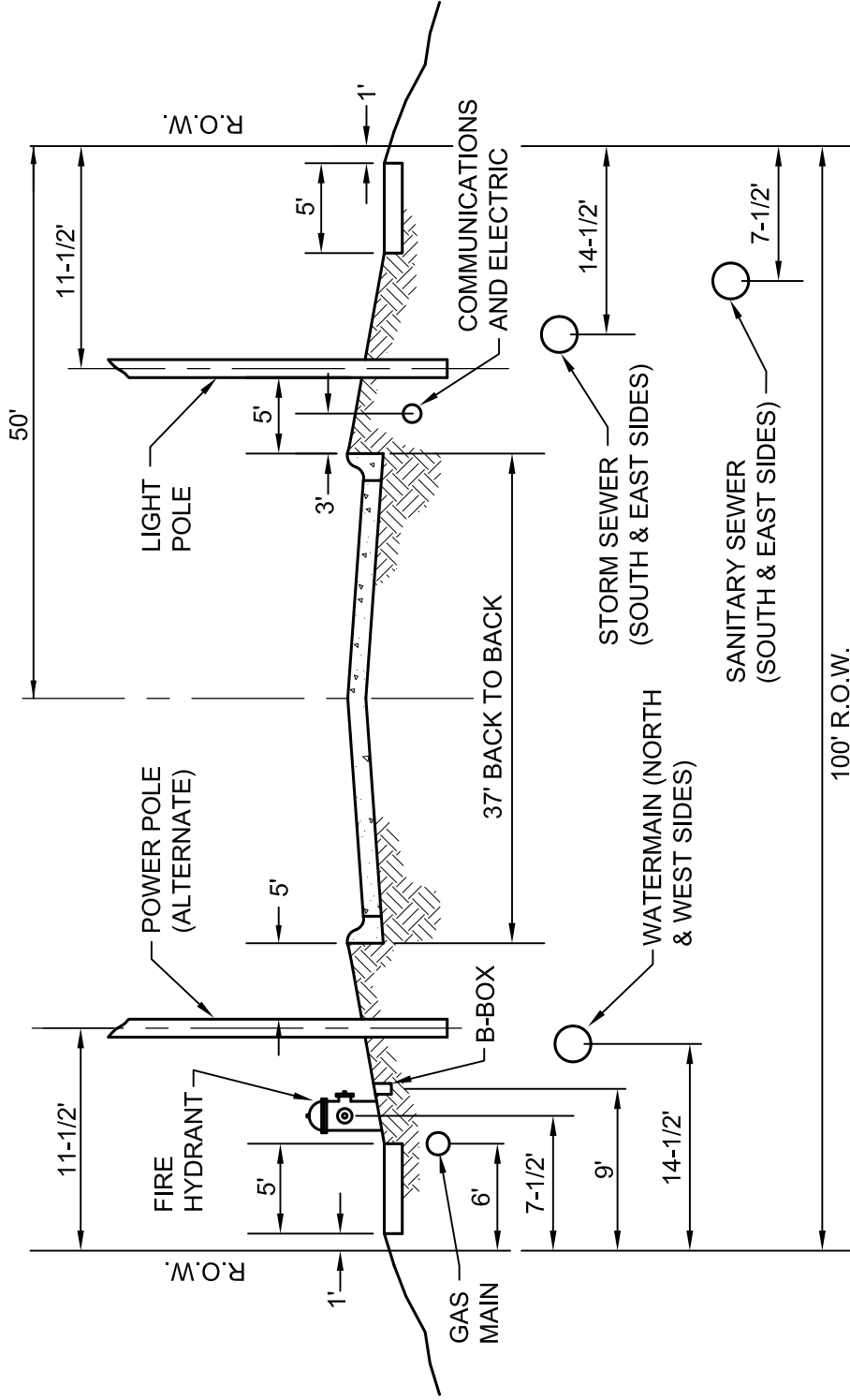

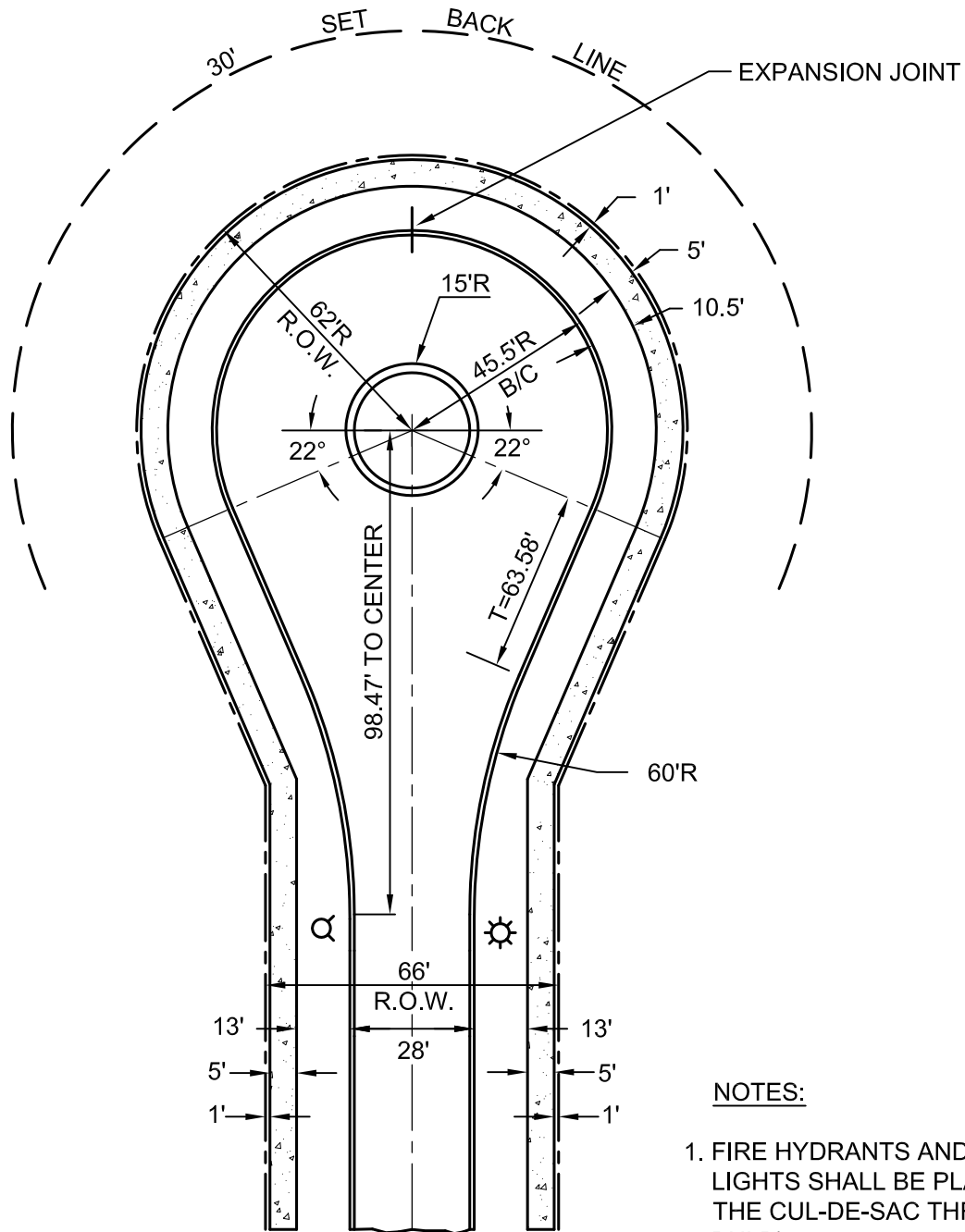

NOTES:

1. FIRE HYDRANTS AND STREET LIGHTS SHALL BE PLACED IN THE CUL-DE-SAC THROAT (NOT BULB).
2. MINIMUM REQUIRED LOT FRONTAGE:
 50' AT PROPERTY LINE
 36.7' AT GUTTER FLOWLINE.
3. MINIMUM PARKWAY WIDTH SHALL BE 10.5'.



City of Naperville
**STANDARD
 DETAIL**

CONCENTRIC CUL-DE-SAC

REVISED: 01/01/2013

SHEET 1 OF 1

PAVEMENT 2

590.02

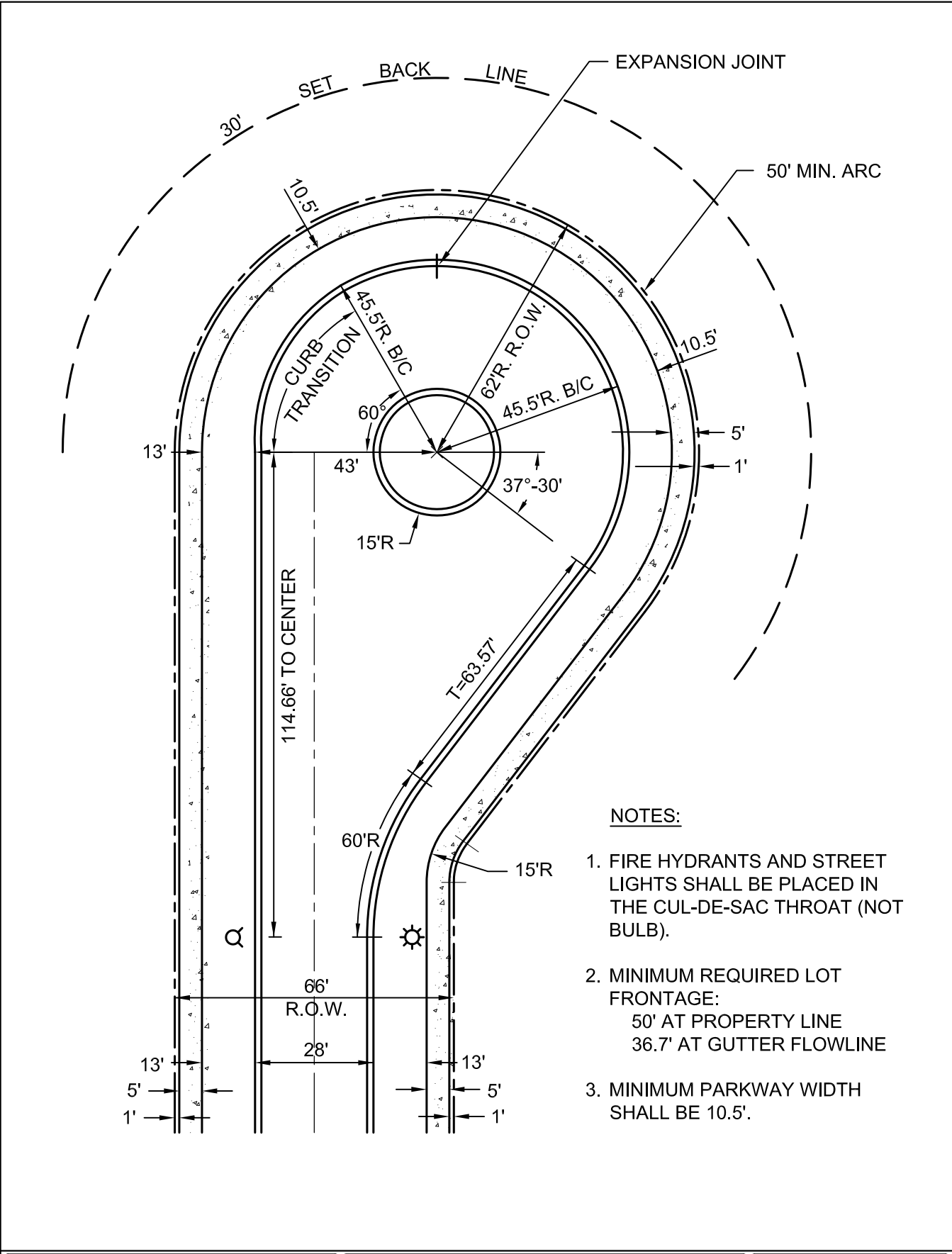

NOTES:

1. FIRE HYDRANTS AND STREET LIGHTS SHALL BE PLACED IN THE CUL-DE-SAC THROAT (NOT BULB).
2. MINIMUM REQUIRED LOT FRONTAGE:
 50' AT PROPERTY LINE
 36.7' AT GUTTER FLOWLINE
3. MINIMUM PARKWAY WIDTH SHALL BE 10.5'.



City of Naperville
**STANDARD
 DETAIL**

ECCENTRIC CUL-DE-SAC

REVISED: 01/01/2013

SHEET 1 OF 1

PAVEMENT 3

590.03

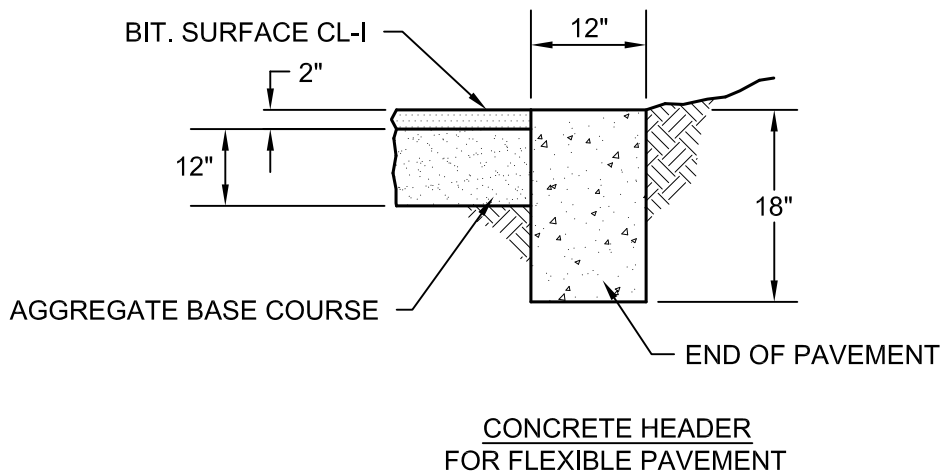
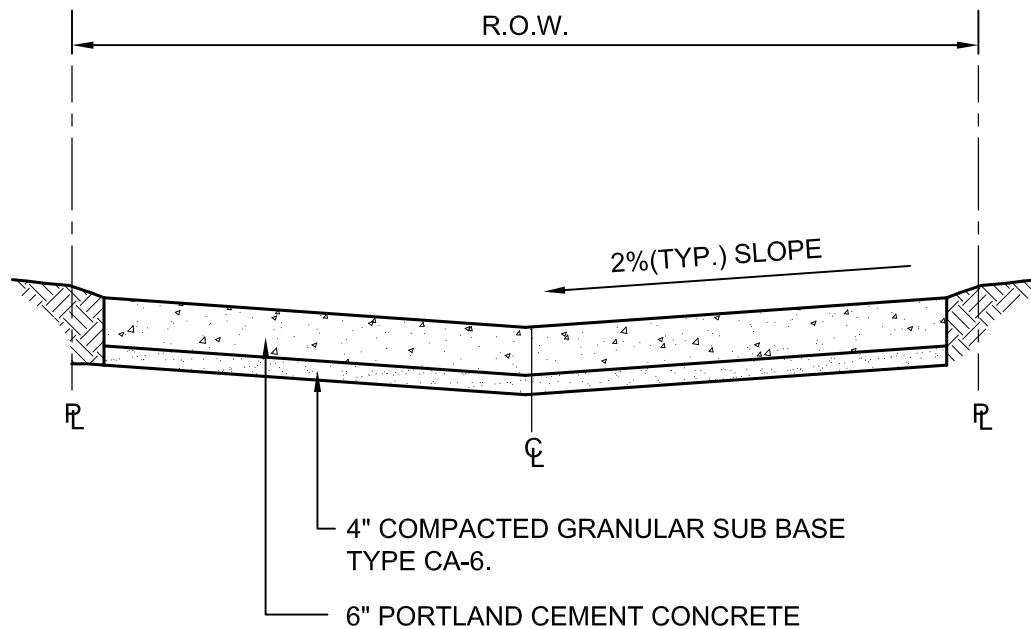

NOTES:

1. CONCRETE HEADER SHALL BE USED WITH FLEXIBLE PAVEMENT OR AT THE DISCRETION OF THE CITY ENGINEER.
2. EXPANSION JOINTS WITH PREMOULDED FILLER SHALL BE PLACED AT THE ENDS OF ALLEY PAVEMENTS WHERE THEY BUTT UP TO STREET RETURNS, AND AT THE EDGES WHERE THEY BUTT UP TO EXISTING STRUCTURES.
3. CONTRACTION JOINTS SHALL BE PLACED EVERY 15' AND/OR AS DIRECTED BY THE ENGINEER.
4. CONTRACTION JOINTS ARE TO BE FILLED WITH A FLEXIBLE, NON-HARDENING JOINT FILLER AS APPROVED BY THE CITY ENGINEER.



City of Naperville
**STANDARD
DETAIL**

TYPICAL ALLEY SECTION

REVISED: 01/01/2013

SHEET 1 OF 1

PAVEMENT 4

590.04

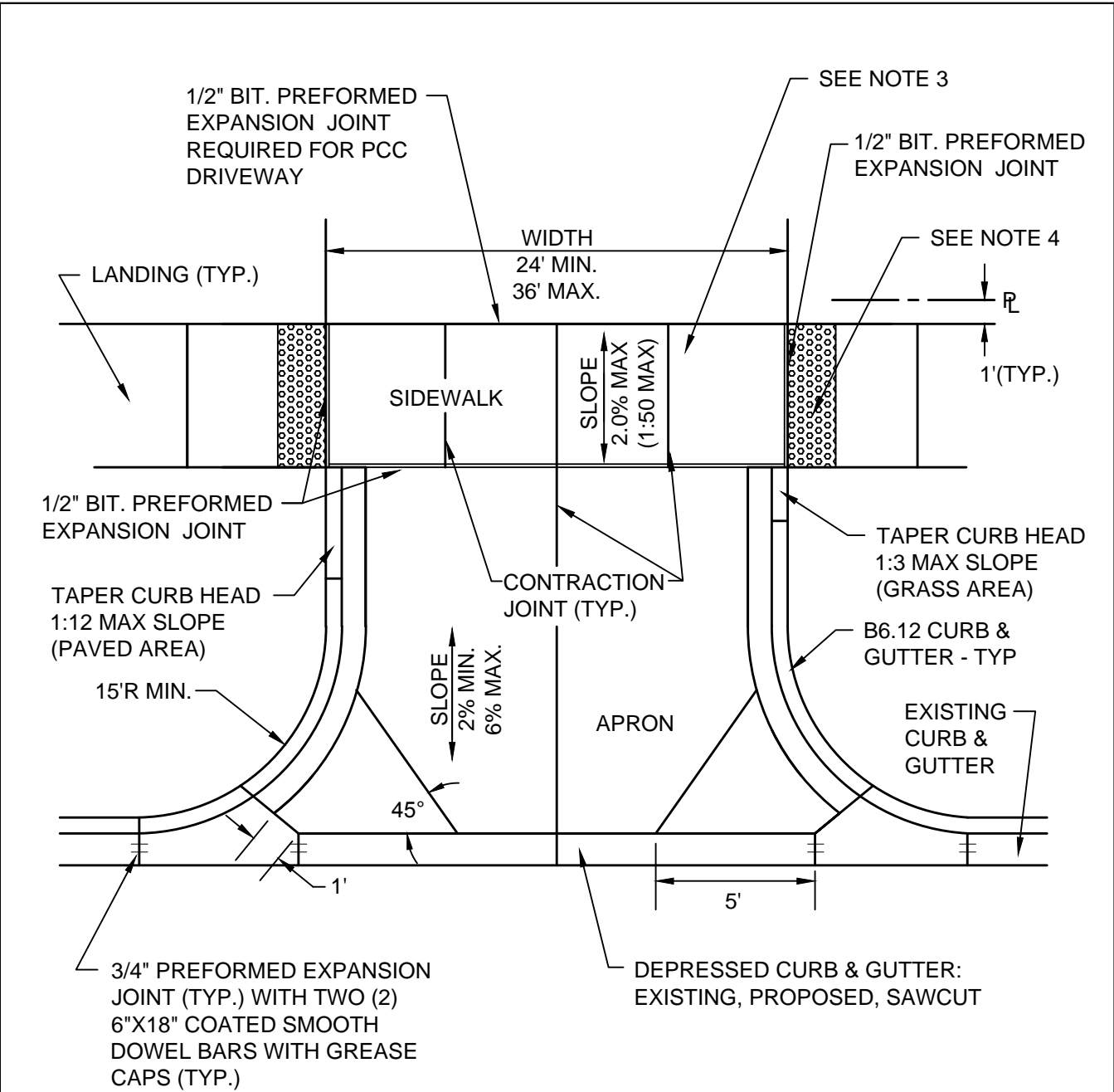

NOTES:

1. ALL AGGREGATE SUB BASE SHALL BE MECHANICALLY COMPACTED.
2. SIDEWALK SHALL CONTINUE THROUGH DRIVEWAYS.
3. SIDEWALK THICKNESS ACROSS DRIVEWAYS SHALL BE A MINIMUM OF 8" PCC ON 4" AGGREGATE SUB BASE.
4. EXPANSION JOINT MATERIAL MUST MATCH THE FULL DEPTH OF THE PAVEMENT.
5. DETECTABLE WARNINGS SHALL ONLY BE INSTALLED AT DRIVEWAYS WITH PERMANENT TRAFFIC CONTROL DEVICES.
6. SIDEWALK CONSTRUCTION SHALL FOLLOW APPLICABLE IDOT STANDARDS.
7. SIDEWALKS SHALL FOLLOW CURRENT ADA GUIDELINES.



City of Naperville
**STANDARD
DETAIL**

**TYPICAL COMMERCIAL
DRIVEWAY DETAIL**

REVISED: 08/01/2018

SHEET 1 OF 1

PAVEMENT 5

590.05

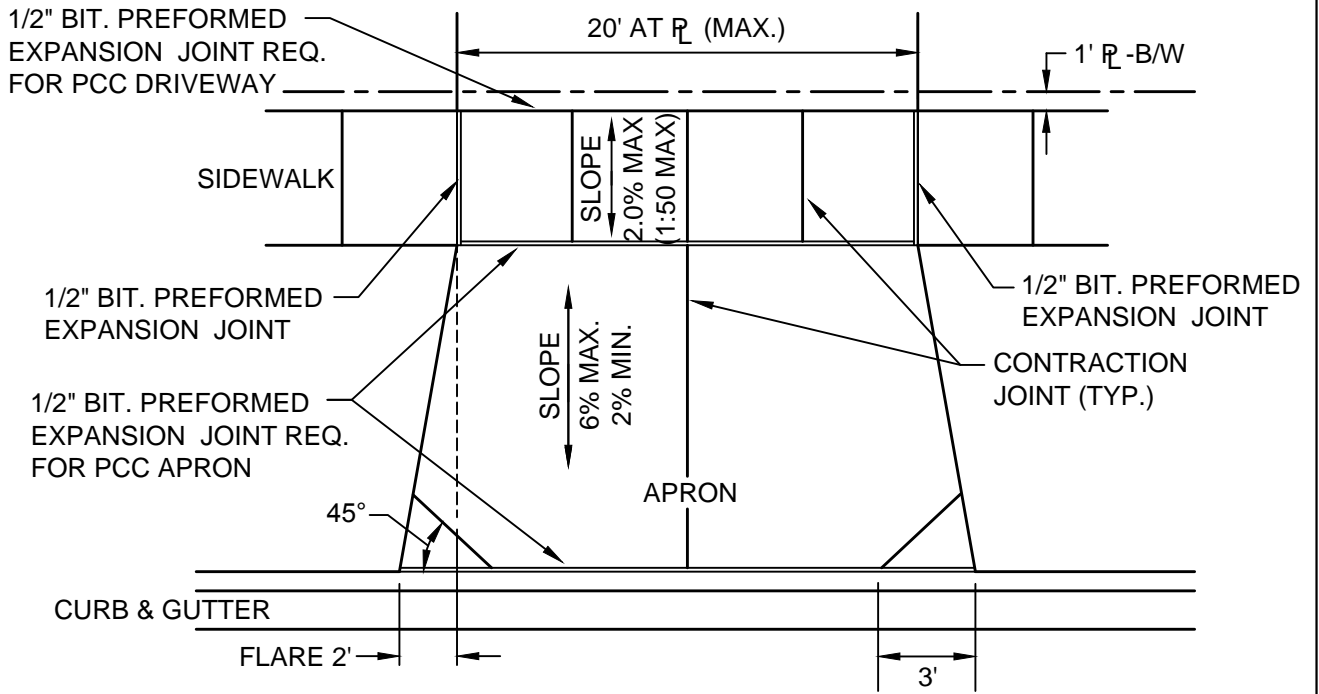

NOTES:

1. DRIVEWAYS SHALL NOT EXCEED 20' IN WIDTH MEASURED AT THE RIGHT-OF-WAY LINE.
2. DRIVEWAYS SHALL NOT ENCROACH OVER THE PROPERTY LINE EXTENSION IN THE PARKWAY.
3. DRIVEWAYS SHALL NOT BE CONSTRUCTED IN EASEMENTS.
4. ALL AGGREGATE SUB-BASE SHALL BE MECHANICALLY COMPACTED.
5. SIDEWALK SHALL CONTINUE THROUGH DRIVEWAYS.
6. SIDEWALK THICKNESS ACROSS DRIVEWAYS SHALL BE A MINIMUM OF 6" PCC ON 2" AGGREGATE SUB BASE.
7. EXPANSION JOINT MATERIAL MUST MATCH THE FULL DEPTH OF THE PAVEMENT.
8. SIDEWALK CONSTRUCTION SHALL FOLLOW APPLICABLE IDOT STANDARDS.
9. SIDEWALKS SHALL FOLLOW CURRENT ADA GUIDELINES.

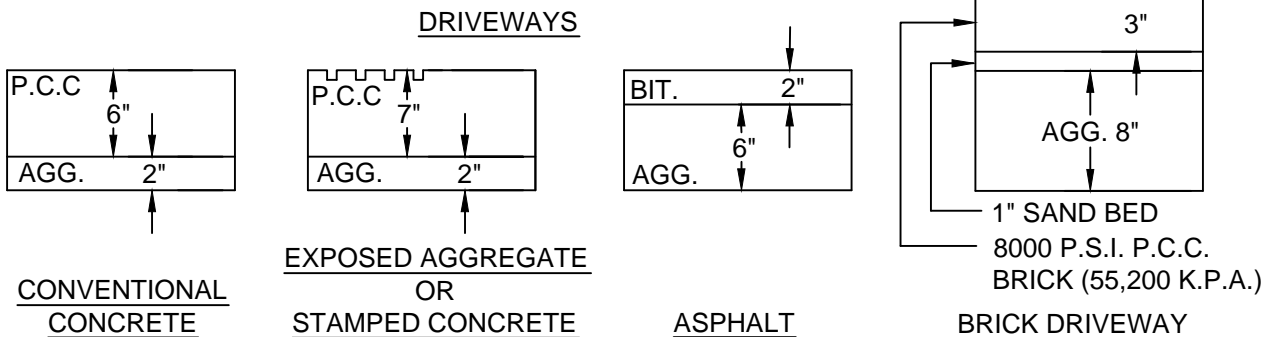
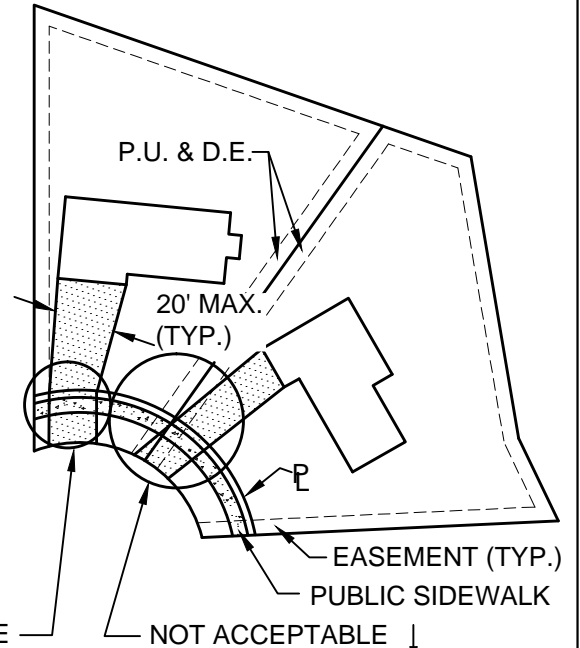

MULTIPLE DRIVEWAYS

F = PROPERTY WIDTH
AT FRONT PROPERTY
LINE

W1 = DRIVEWAY WIDTH AT
PROPERTY LINE

W2 = DRIVEWAY WIDTH AT
PROPERTY LINE

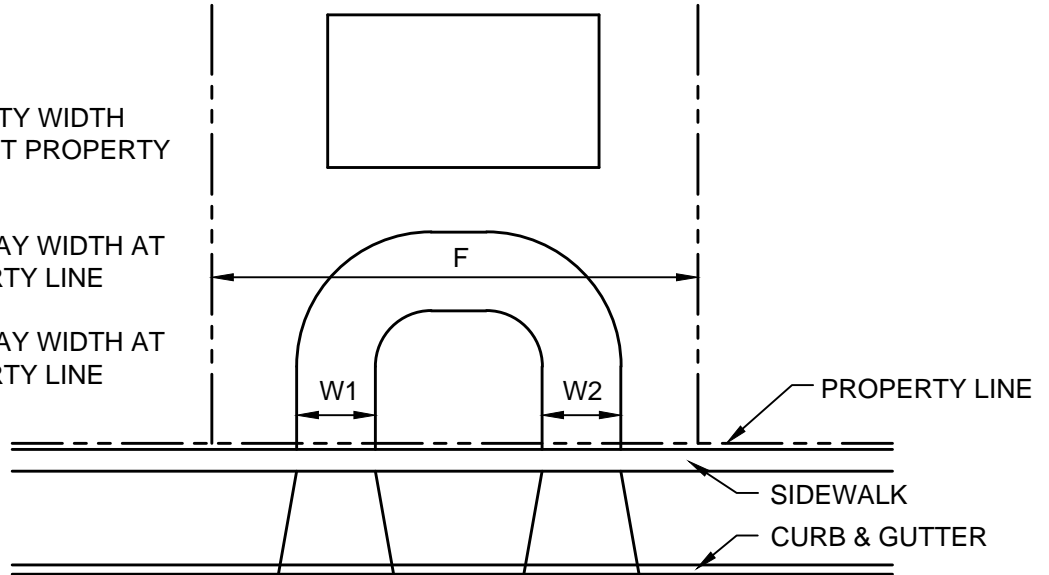

FOR MULTIPLE DRIVEWAYS TO BE PERMITTED, THE FOLLOWING CONDITIONS MUST BE MET:

1. THE PROPERTY WIDTH (F) MUST BE GREATER THAN 75'.
2. $(F/75)(20) \geq W1+W2$

RESIDENTIAL DRIVEWAY NEAR INTERSECTION

ON THE FAR SIDE OF AN INTERSECTION, THE EDGE OF THE DRIVEWAY AT THE CURB MUST BE AT LEAST 10' FROM THE PROPERTY LINE EXTENDED.

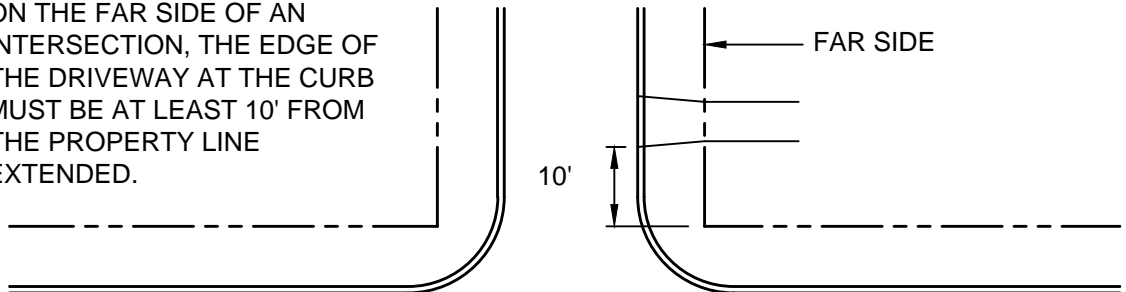

ON THE NEAR SIDE OF AN INTERSECTION, THE EDGE OF THE DRIVEWAY AT THE CURB MUST BE AT LEAST 20' FROM THE PROPERTY LINE EXTENDED.

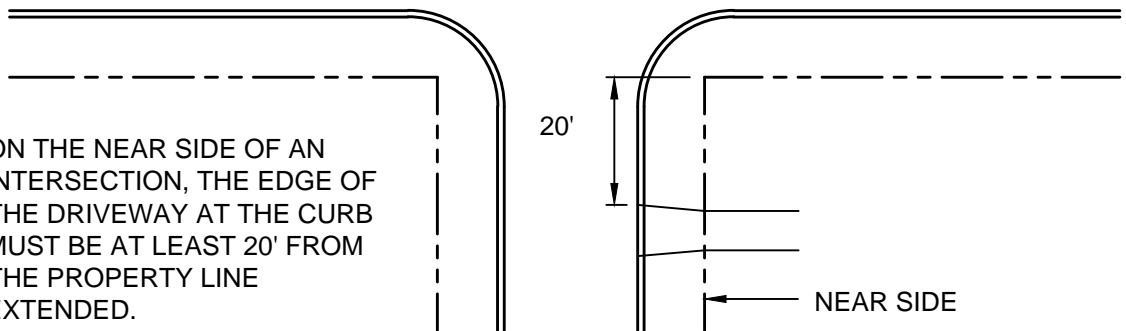

City of Naperville
**STANDARD
DETAIL**

**TYPICAL RESIDENTIAL
DRIVEWAY DETAIL**

REVISED: 08/01/2018

SHEET 2 OF 2

PAVEMENT 6

590.06

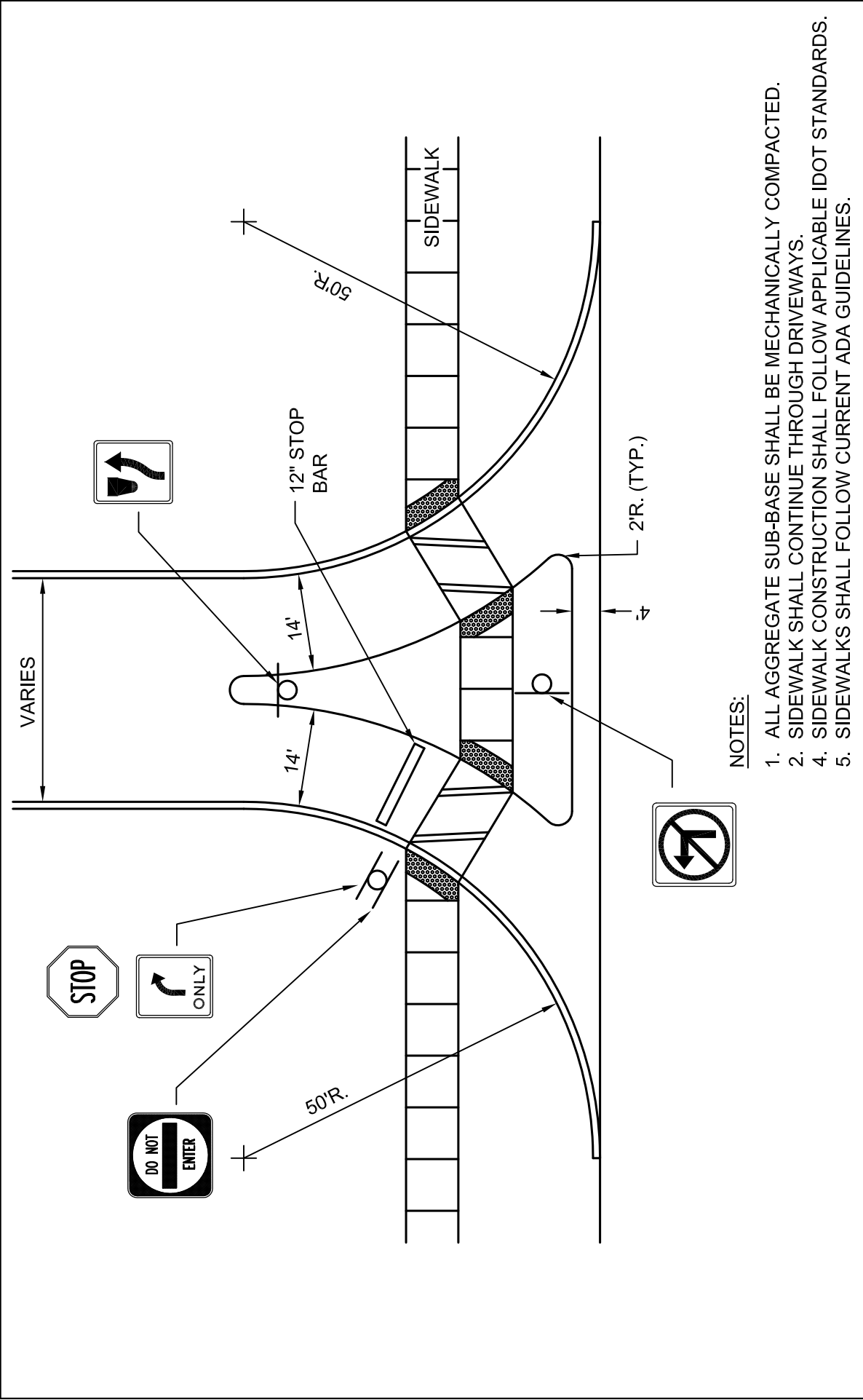

NOTES:

1. ALL AGGREGATE SUB-BASE SHALL BE MECHANICALLY COMPACTED.
2. SIDEWALK SHALL CONTINUE THROUGH DRIVEWAYS.
4. SIDEWALK CONSTRUCTION SHALL FOLLOW APPLICABLE IDOT STANDARDS.
5. SIDEWALKS SHALL FOLLOW CURRENT ADA GUIDELINES.



City of Naperville
**STANDARD
 DETAIL**

TYPICAL RIGHT-IN/RIGHT-OUT ACCESS

PAVEMENT 7

590.07

REVISED: 01/01/2013

SHEET 1 OF 1

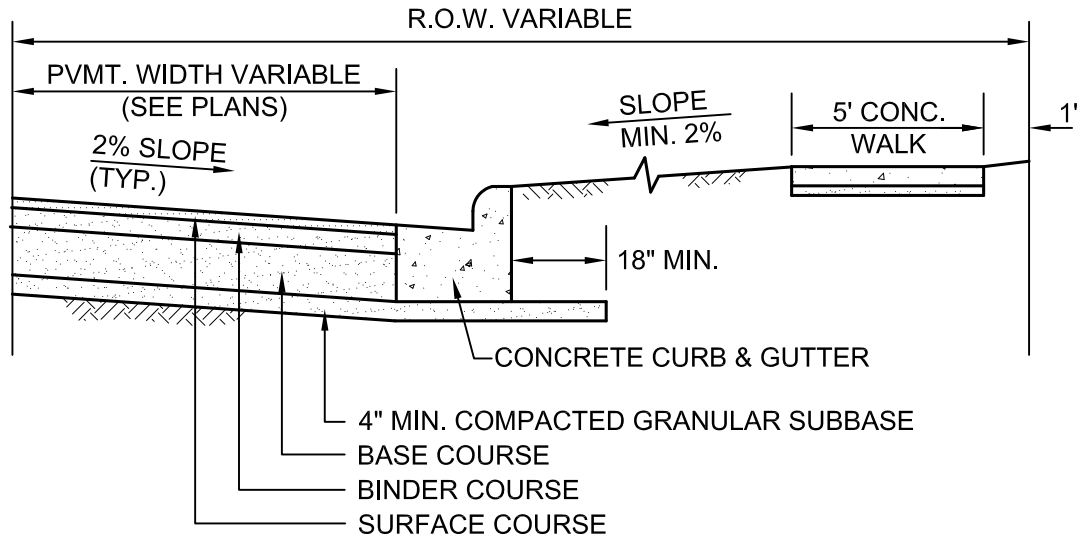

FLEXIBLE PAVEMENT

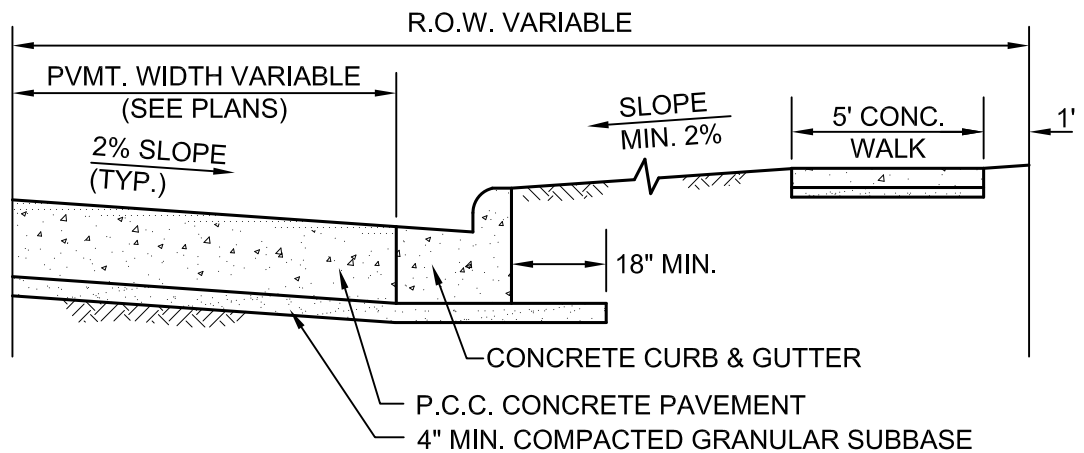

RIGID PAVEMENT



City of Naperville
**STANDARD
DETAIL**

TYPICAL PAVEMENT DETAILS

REVISED: 01/01/2013

SHEET 1 OF 1

PAVEMENT 10

590.10

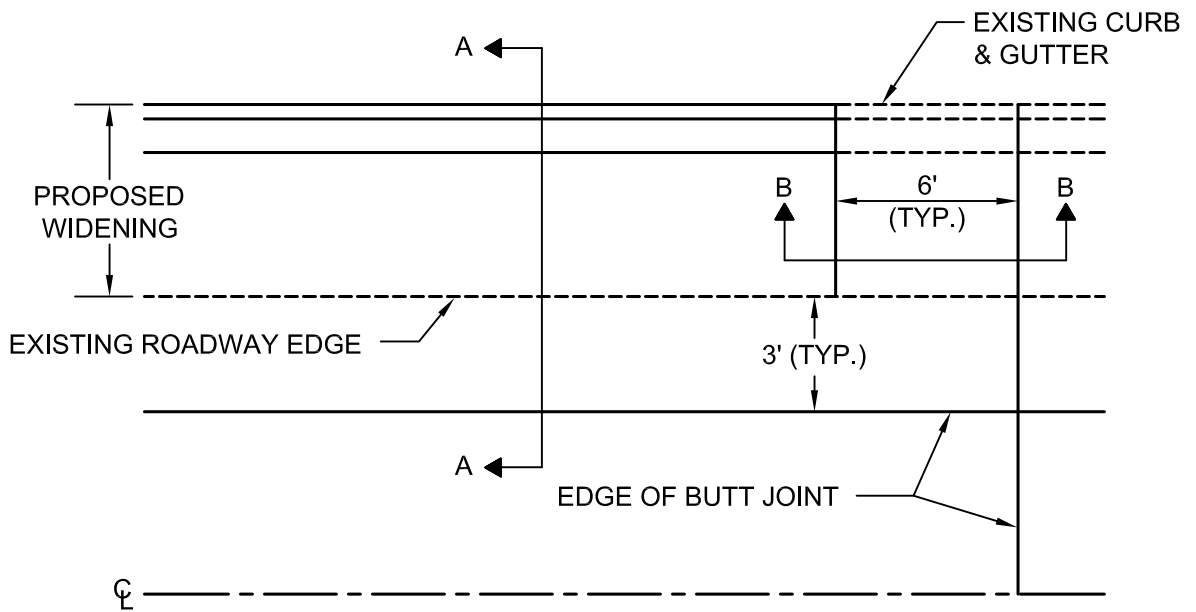

NOTE:

FOR WIDENING LESS THAN 8' WHERE COMPACTION IS DIFFICULT, CONCRETE SHALL BE USED.

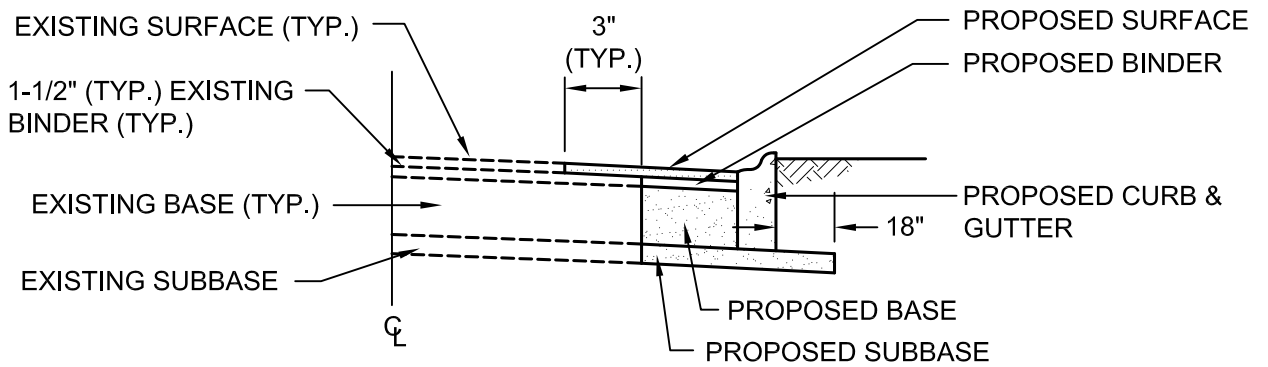

SECTION A-A

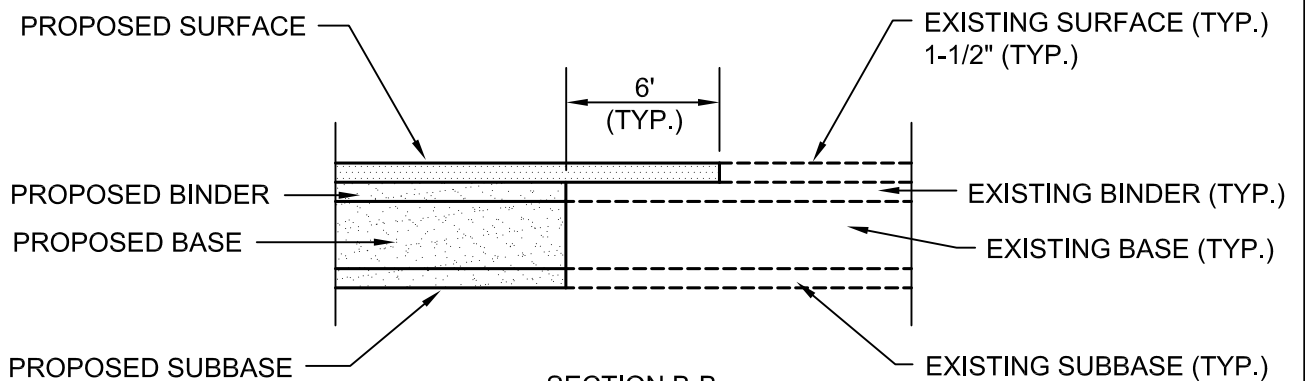

SECTION B-B



City of Naperville
**STANDARD
DETAIL**

BUTT JOINT DETAIL

REVISED: 01/01/2013

SHEET 1 OF 1

PAVEMENT 11

590.11

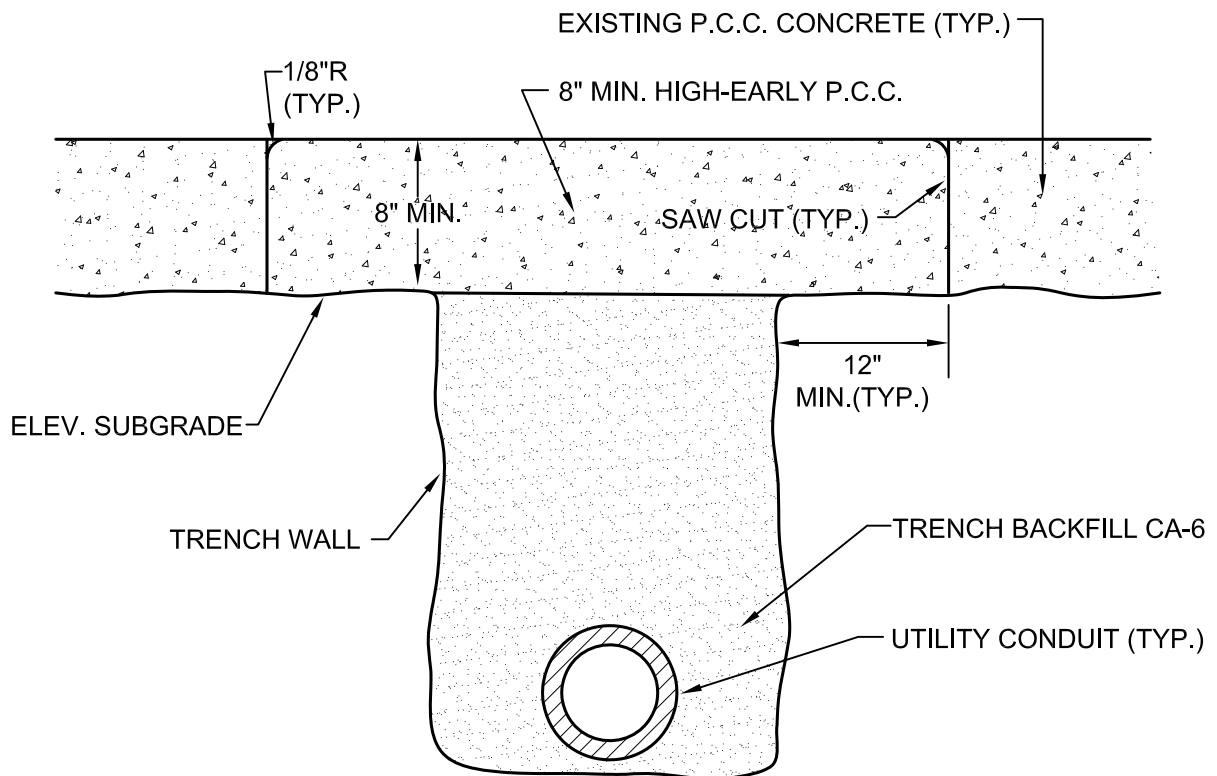

NOTES:

1. THE TRENCH SHALL BE BACKFILLED WITH AGGREGATE (CA-6) AND COMPACTED TO 95% OF THE STANDARD PROCTOR DENSITY. TRENCH SPOILS OR EXCAVATED MATERIAL SHALL BE DISCARDED BY THE CONTRACTOR, AT HIS EXPENSE, AT DUMP SITES OR IN A SUITABLE FASHION AS APPROVED BY THE CITY ENGINEER.
2. PRIOR TO PLACING OF P.C.C. CONCRETE, THE EXPOSED EDGES OF ALL EXISTING PAVEMENT SHALL BE SAW CUT TO PROVIDE A SMOOTH, CLEAN EDGE, FREE OF LOOSE MATERIAL.
3. EXCAVATIONS SHALL BE PROTECTED BY BARRICADES WITH FLASHING LIGHTS. A 1" STEEL PLATE SHALL BE PROVIDED AND MAINTAINED BY THE CONTRACTOR AT LOCATIONS WHERE ADJUSTMENTS ARE LOCATED IN TRAVEL LANES UNTIL THE SURFACE RESTORATION IS COMPLETE. THE PLATE SHALL BE PROTECTED FROM SLIDING AND PROVIDED WITH BITUMINOUS RAMPS.
4. TRENCH TO BE COMPACTED IN CONFORMANCE WITH ARTICLE 603.08 OF THE IDOT STANDARD SPECIFICATIONS FOR ROAD AND BRIDGE CONSTRUCTION.



City of Naperville
**STANDARD
 DETAIL**

**UTILITY TRENCH PAVING SECTION
 (RIGID PAVEMENTS)**

REVISED: 01/01/2013

SHEET 1 OF 1

PAVEMENT 12

590.12

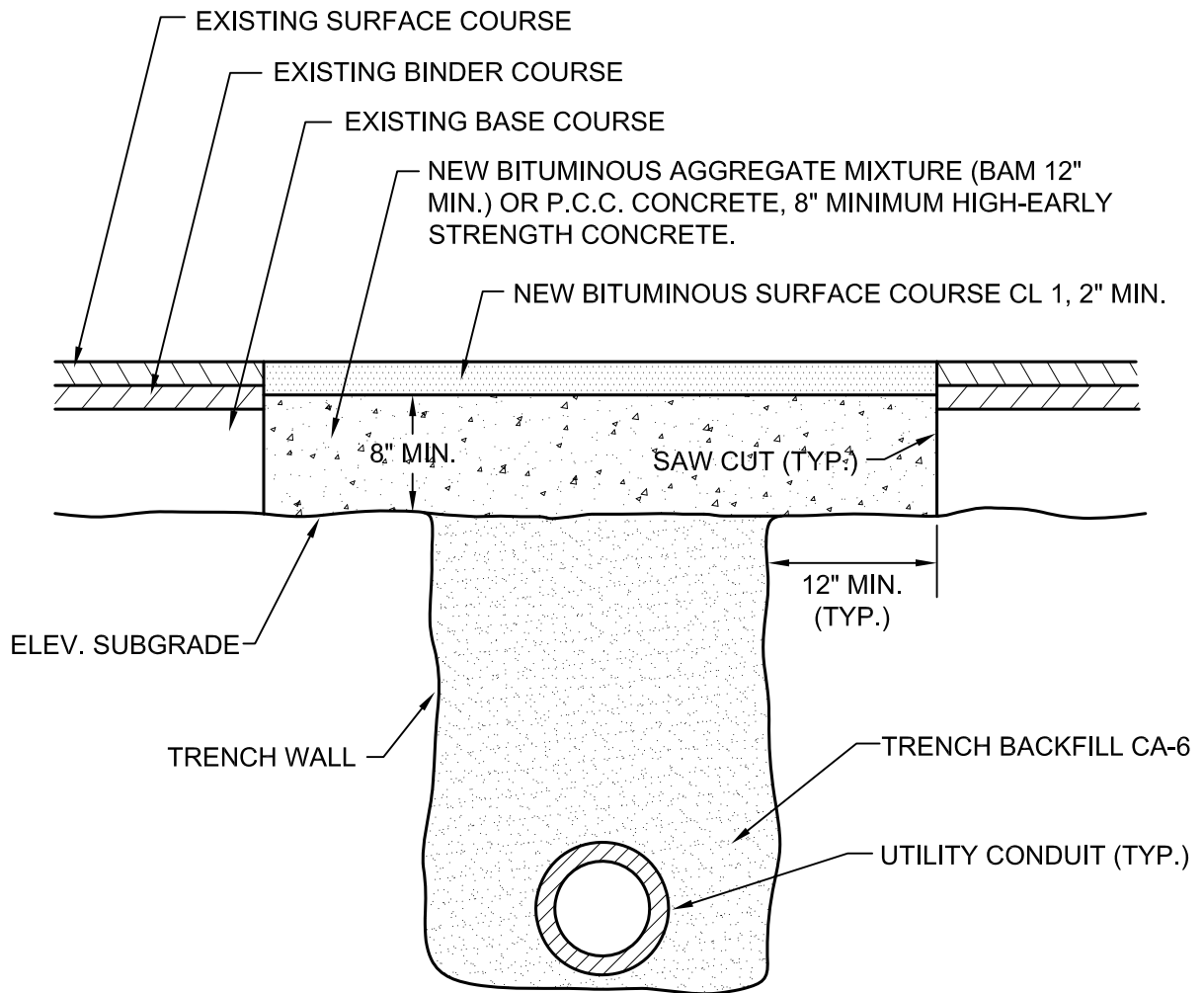

NOTES:

1. THE TRENCH SHALL BE BACKFILLED WITH AGGREGATE (CA-6) AND COMPACTED TO 95% OF THE STANDARD PROCTOR DENSITY. TRENCH SPOILS OR EXCAVATED MATERIAL SHALL BE DISCARDED BY THE CONTRACTOR, AT HIS EXPENSE, AT DUMP SITES OR IN A SUITABLE FASHION AS APPROVED BY THE CITY ENGINEER.
2. PRIOR TO PLACING OF P.C.C. CONCRETE, THE EXPOSED EDGES OF ALL EXISTING PAVEMENT SHALL BE SAW CUT TO PROVIDE A SMOOTH, CLEAN EDGE, FREE OF LOOSE MATERIAL.
3. EXCAVATIONS SHALL BE PROTECTED BY BARRICADES WITH FLASHING LIGHTS. A 1" STEEL PLATE SHALL BE PROVIDED AND MAINTAINED BY THE CONTRACTOR AT LOCATIONS WHERE ADJUSTMENTS ARE LOCATED IN TRAVEL LANES UNTIL THE SURFACE RESTORATION IS COMPLETE. THE PLATE SHALL BE PROTECTED FROM SLIDING AND PROVIDED WITH BITUMINOUS RAMPS.
4. TRENCH TO BE COMPACTED IN CONFORMANCE WITH ARTICLE 603.08(METHOD 3) OF THE IDOT STANDARD SPECIFICATIONS FOR ROAD AND BRIDGE CONSTRUCTION.



City of Naperville
**STANDARD
 DETAIL**

**UTILITY TRENCH PAVING SECTION
 (FLEXIBLE PAVEMENTS)**

REVISED: 01/01/2013

SHEET 1 OF 1

PAVEMENT 13

590.13

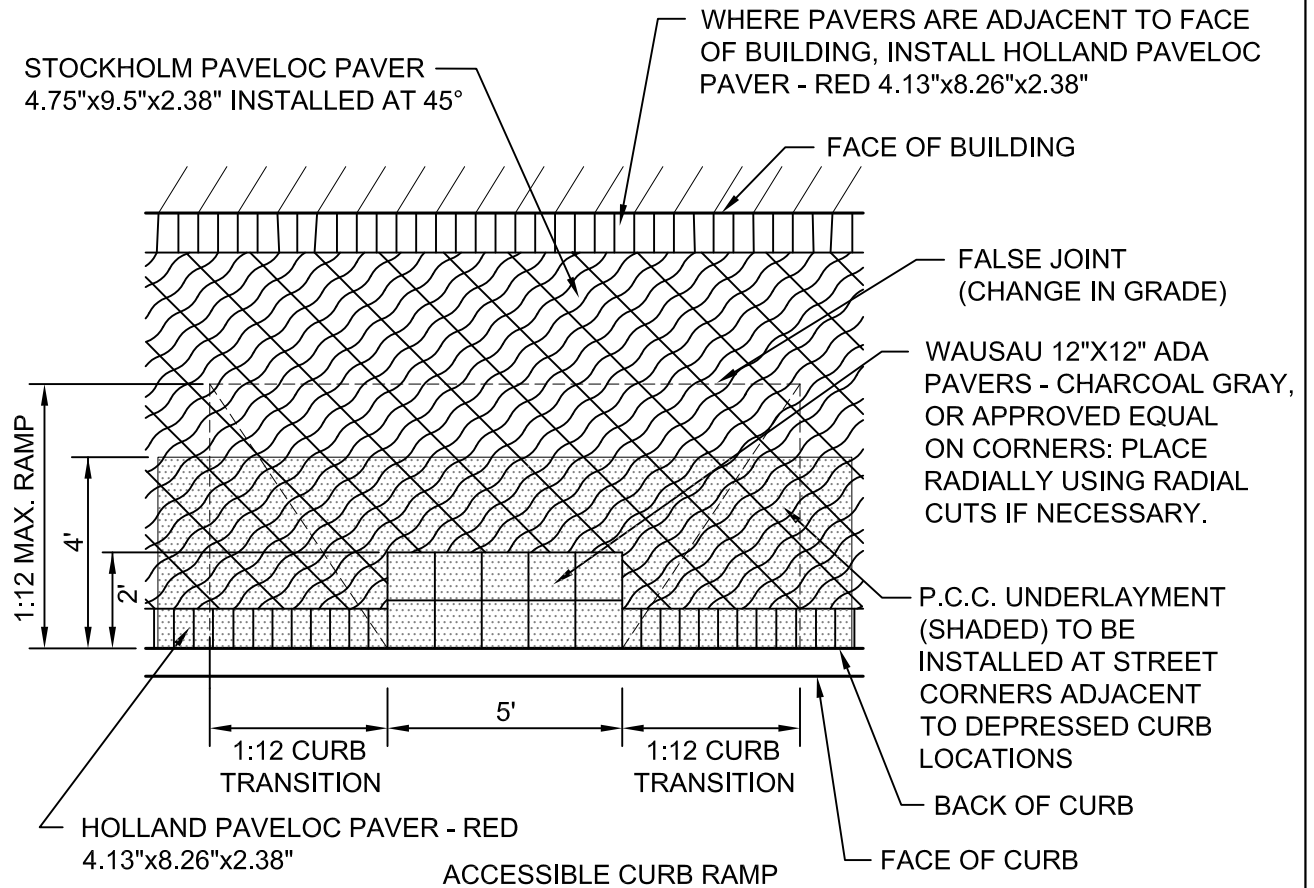
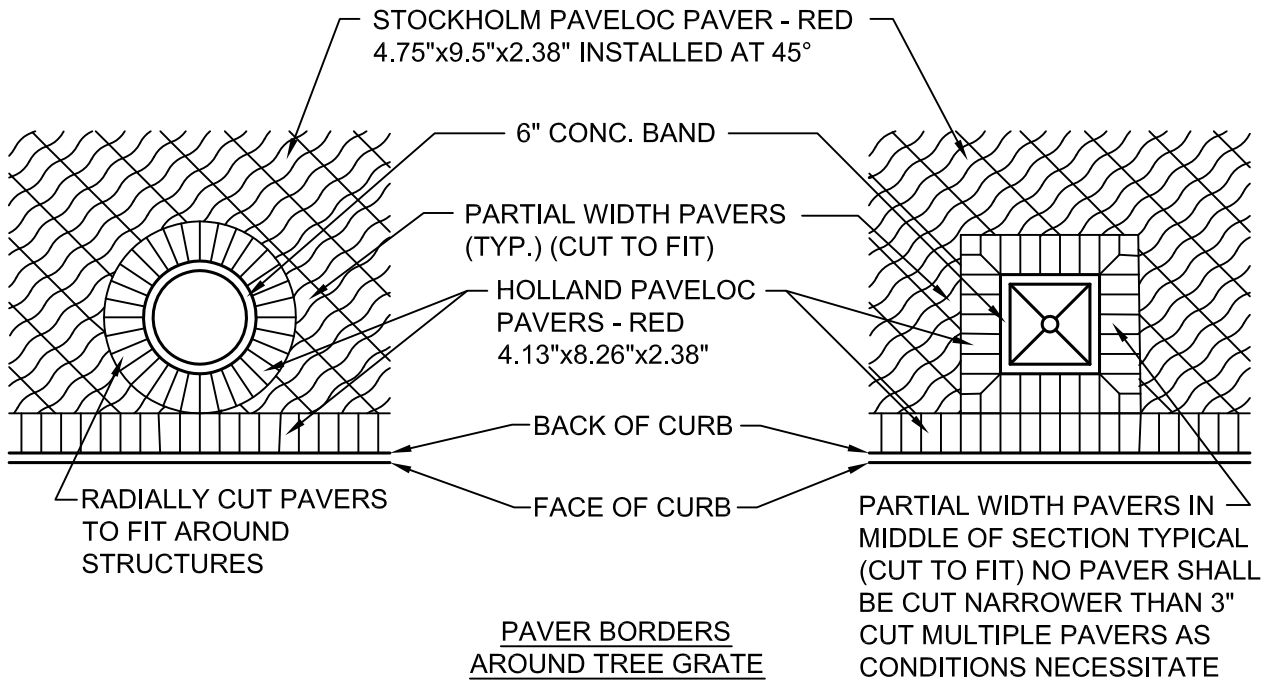

City of Naperville
**STANDARD
DETAIL**

**DOWNTOWN STREETSCAPE
PAVEMENT SECTION**

REVISED: 06/14/2013

SHEET 1 OF 2

PAVEMENT 14

590.14

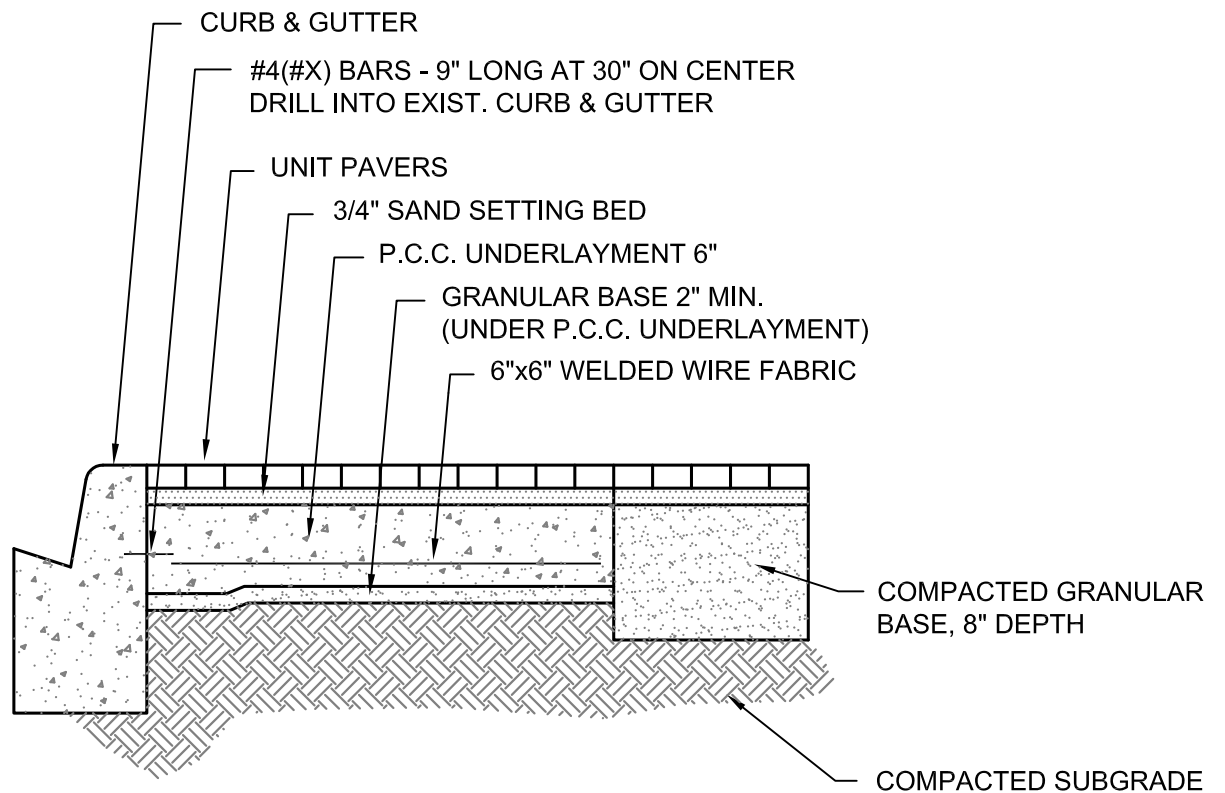
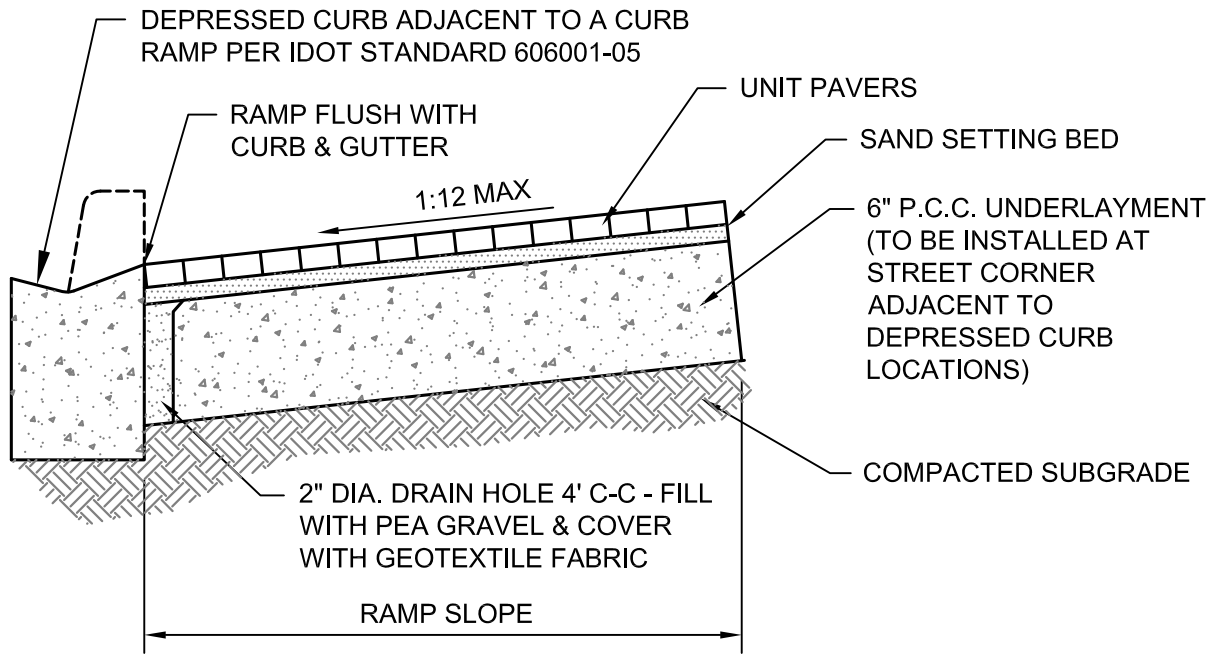

NOTE:
 AT HANDICAP CURB RAMPS, CURBS WILL BE DEPRESSED.

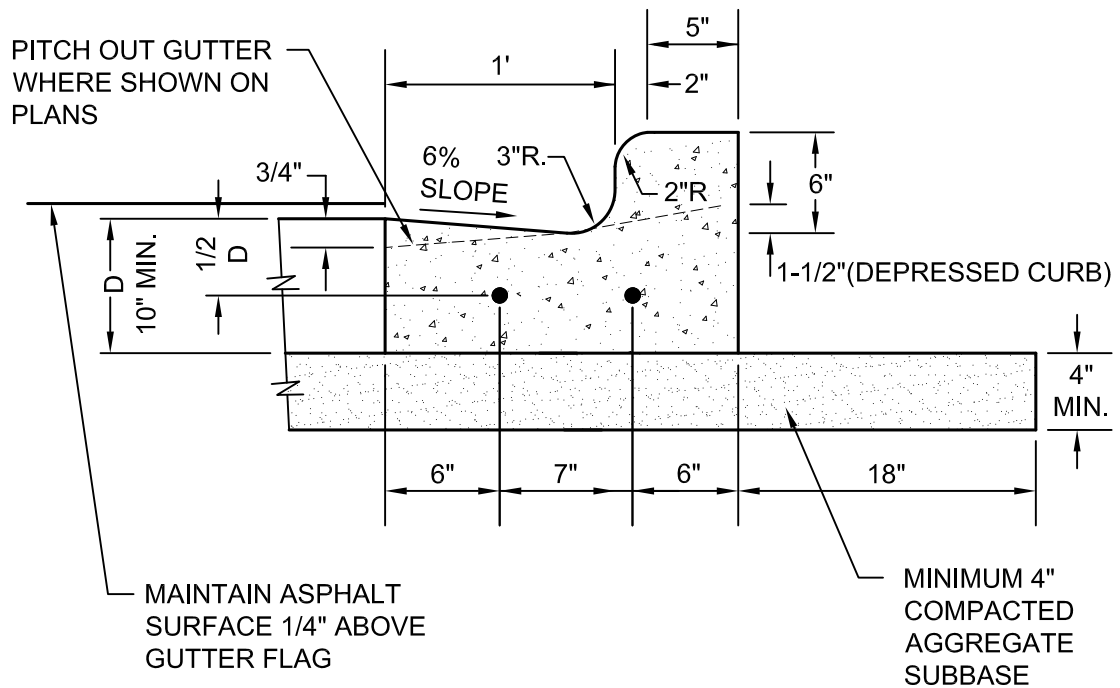

NOTES:

1. 3/4" PREFORMED BITUMINOUS EXPANSION JOINT WITH TWO (2) NUMBER 6 COATED SMOOTH DOWEL BARS (3/4" DIA. X 18") WITH GREASE CAPS SHALL BE PLACED EVERY 150', 10' EITHER SIDE OF DRAINAGE STRUCTURES, P.C.'S, RADIUS POINTS AND BACK OF CUL-DE-SACS. WHEN EXPANSION JOINTS ARE CONSTRUCTED ADJACENT TO EXISTING CURB & GUTTER THE EXISTING CURB SHALL BE DRILLED AND TWO (2) NUMBER 6 COATED SMOOTH DOWEL BARS (3/4" X 18") GROUTED IN PLACE. GREASE CAPS SHALL BE PLACED ON THE SIDE OF THE NEW CURB AND GUTTER SHALL HAVE A PINCHED STOP THAT WILL PROVIDE A MINIMUM 1" EXPANSION.
2. TOOLED CONTROL JOINTS OR SAWCUTS SHALL BE MADE EVERY 15'.
3. SAWCUTS SHALL BE MADE WITHIN TWENTY-FOUR (24) HOURS AND SEALED WITH A CITY APPROVED JOINT SEALANT. JOINTS SHALL BE CLEAN AND DRY PRIOR TO APPLICATION OF SEALANT.
4. FOR CURB AND GUTTER CONSTRUCTED OVER UTILITY TRENCHES, TWO (2) EPOXY COATED REINFORCING BARS (NO. 4) SHALL BE PLACED IN THE CURB AND GUTTER, CENTERED OVER THE TRENCH.



City of Naperville
**STANDARD
 DETAIL**

B6.12 BARRIER CURB & GUTTER

REVISED: 01/01/2013

SHEET 1 OF 1

PAVEMENT 20

590.20

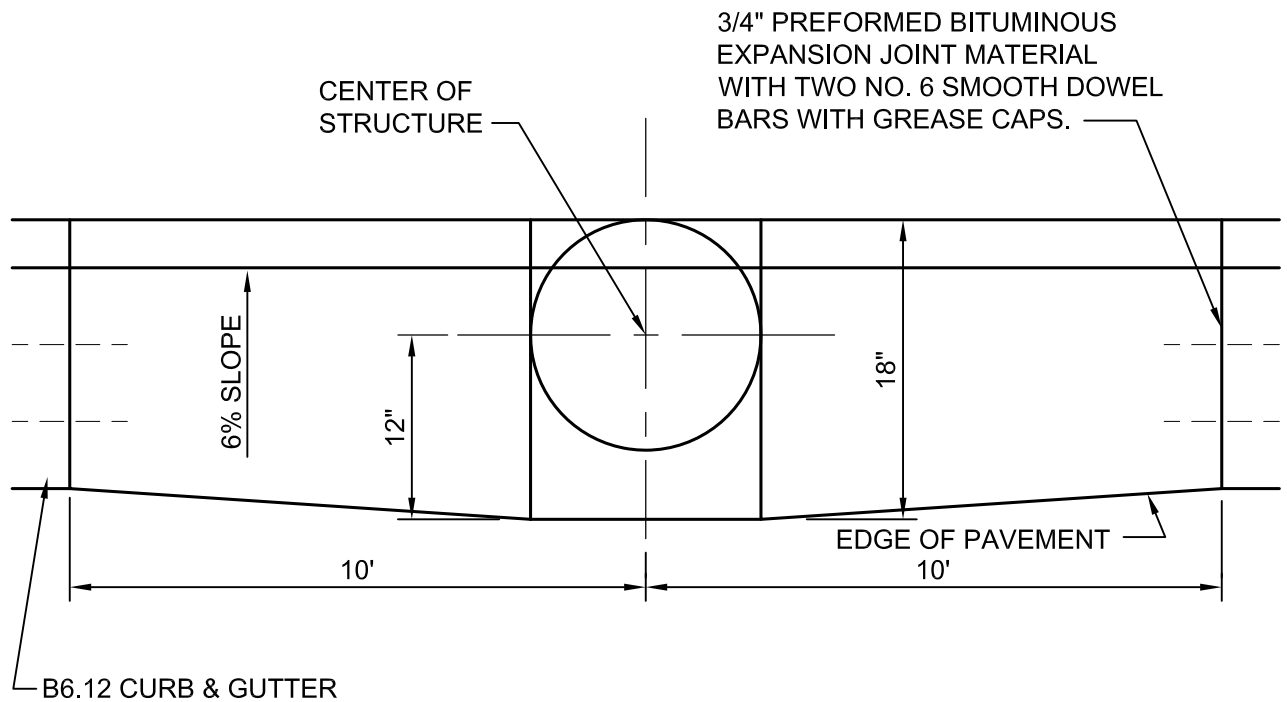

PLAN

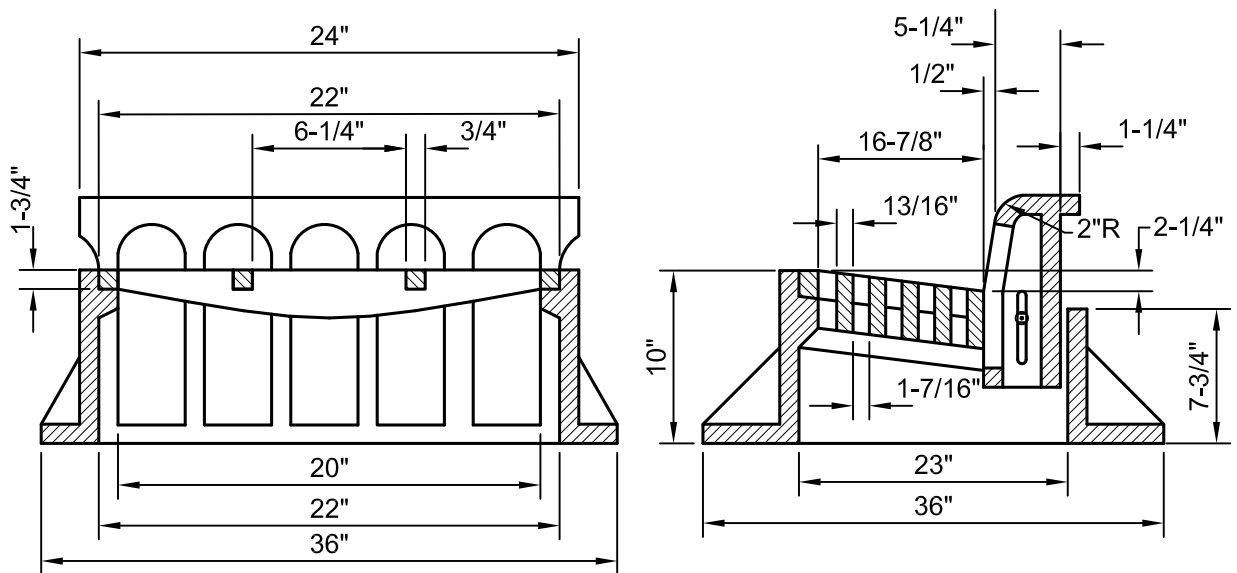

NOTES:

1. GRATE & CASTING SHALL BE EAST JORDAN 7220 OR NEENAH R-3278-A OR AS APPROVED BY THE CITY ENGINEER.
2. ALL CASTINGS SHALL BE SHOP PAINTED WITH AN ASPHALTIC BASE.



City of Naperville
**STANDARD
DETAIL**

**B6.12 BARRIER CURB & GUTTER
AT CURB INLETS**

REVISED: 01/01/2013

SHEET 1 OF 1

PAVEMENT 21

590.21

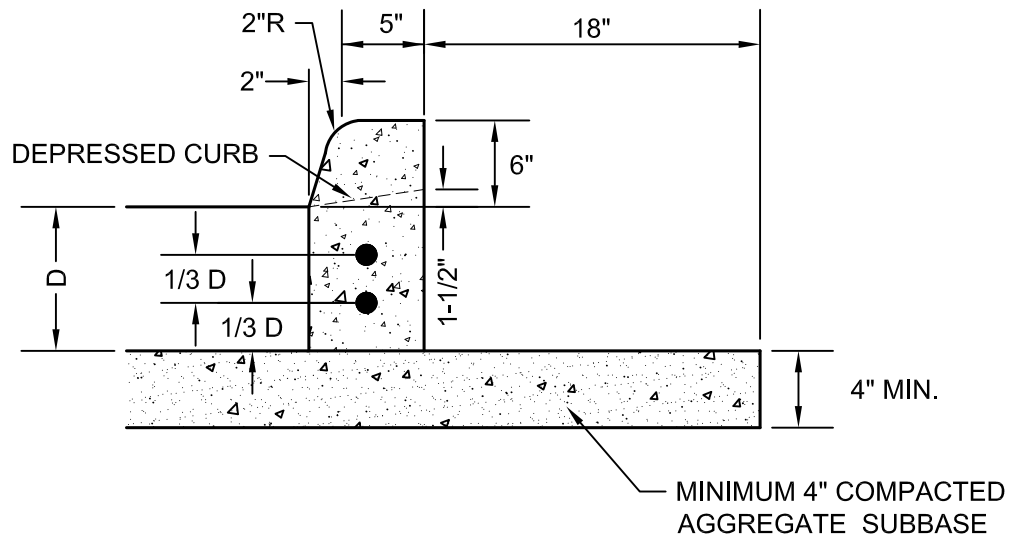

NOTES:

1. 3/4" PREFORMED BITUMINOUS EXPANSION JOINT WITH TWO (2) NUMBER 6 COATED SMOOTH DOWEL BARS (3/4" DIA. X 18") WITH GREASE CAPS SHALL BE PLACED EVERY 150', 10' EITHER SIDE OF DRAINAGE STRUCTURES, P.C.'S, RADIUS POINTS AND BACK OF CUL-DE-SACS. WHEN EXPANSION JOINTS ARE CONSTRUCTED ADJACENT TO EXISTING CURB & GUTTER THE EXISTING CURB SHALL BE DRILLED AND TWO (2) NUMBER 6 COATED SMOOTH DOWEL BARS (3/4" X 18") GROUTED IN PLACE. GREASE CAPS SHALL BE PLACED ON THE SIDE OF THE NEW CURB AND GUTTER SHALL HAVE A PINCHED STOP THAT WILL PROVIDE A MINIMUM 1" EXPANSION.
2. TOOLED CONTROL JOINTS OR SAWCUTS SHALL BE MADE EVERY 15'.
3. SAWCUTS SHALL BE MADE WITHIN TWENTY-FOUR (24) HOURS AND SEALED WITH A CITY APPROVED JOINT SEALANT. JOINTS SHALL BE CLEAN AND DRY PRIOR TO APPLICATION OF SEALANT.
4. FOR CURB AND GUTTER CONSTRUCTED OVER UTILITY TRENCHES, TWO (2) EPOXY COATED REINFORCING BARS (NO. 4) SHALL BE PLACED IN THE CURB AND GUTTER, CENTERED OVER THE TRENCH.



City of Naperville
**STANDARD
 DETAIL**

TYPE B BARRIER CURB

REVISED: 01/01/2013

SHEET 1 OF 1

PAVEMENT 23

590.23

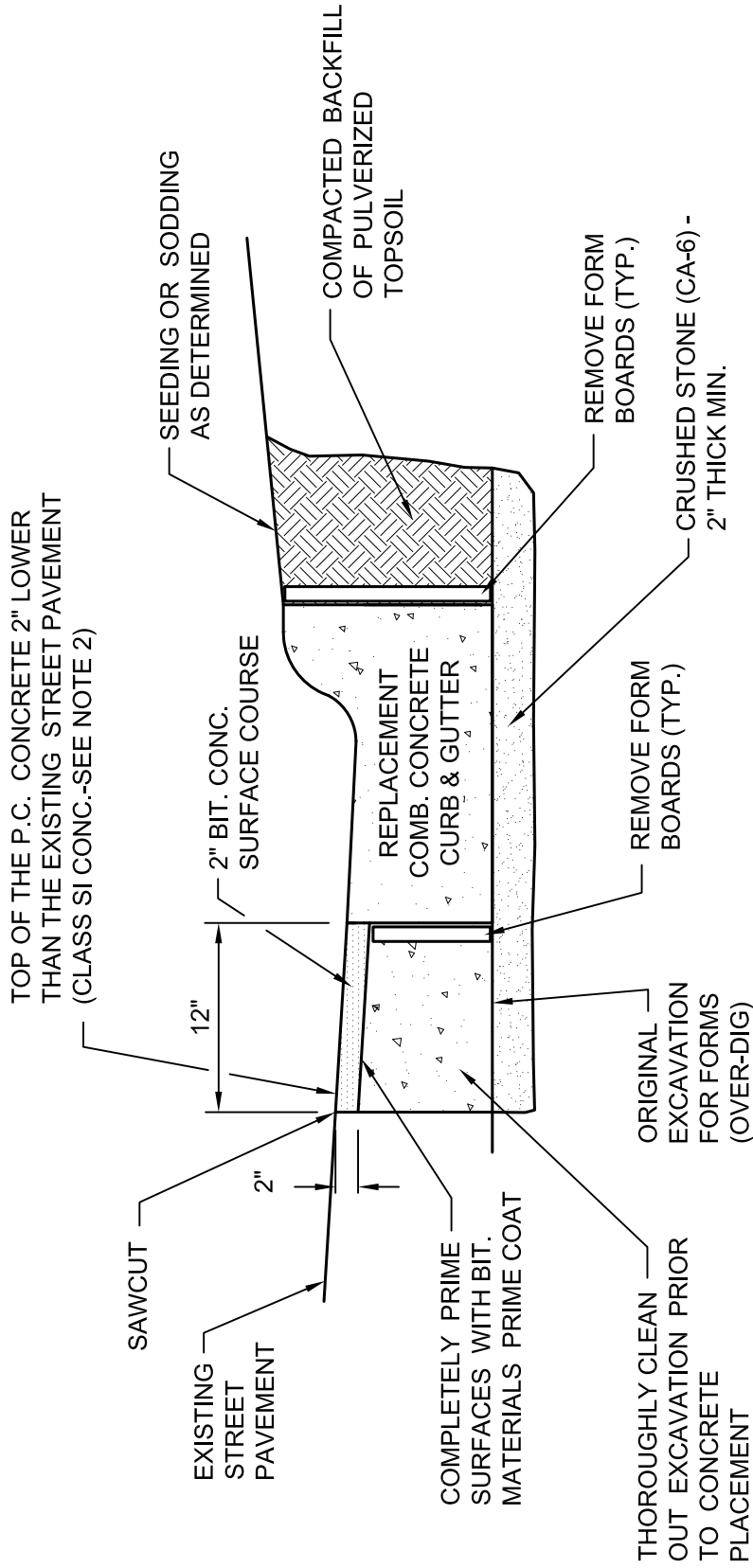

NOTES:

1. THE COMPLETE REPAIR OF PAVEMENTS ADJACENT TO THE REPLACEMENT CONCRETE CURB AND GUTTER IS INCLUDED IN THE COST OF THE NEW CURB AND GUTTER.
2. CLASS SI CONCRETE SHALL BE POURED SEPARATELY FROM THE CURB ONCE THE FORM BOARDS HAVE BEEN REMOVED.



City of Naperville
**STANDARD
 DETAIL**

CURB REPLACEMENT

REVISED: 05/15/2015

SHEET 1 OF 1

PAVEMENT 24

590.24

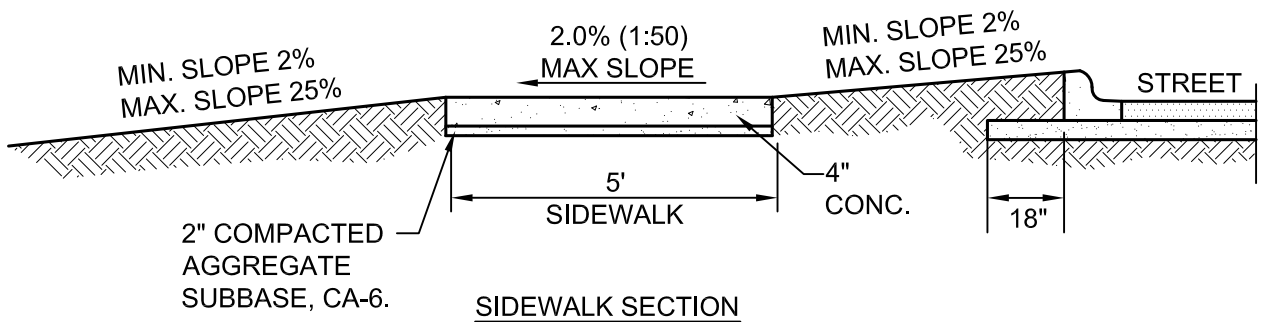
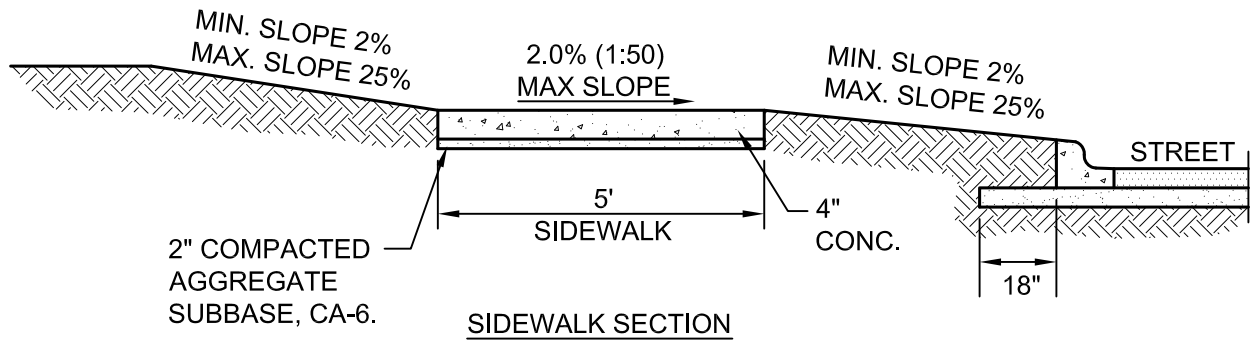

NOTES:

1. CONCRETE SHALL BE IDOT CLASS SI.
2. MINIMUM SIDEWALK THICKNESS SHALL BE 4".
3. SIDEWALK THICKNESS ACROSS DRIVEWAYS SHALL BE AT A MINIMUM 6" FOR RESIDENTIAL DRIVEWAYS AND 8" FOR COMMERCIAL DRIVEWAYS.
4. MAXIMUM LONGITUDINAL SLOPE SHALL NOT EXCEED 5% (20:1). FOR ANY SLOPE IN EXCESS OF 5%, ALL REQUIREMENTS OF THE ILLINOIS ACCESSIBILITY CODE (LATEST EDITION) SHALL BE MET.
5. MINIMUM TRANSVERSE SLOPE SHALL BE 1.0% (1:100). MAXIMUM TRANSVERSE SLOPE SHALL BE 2.0% (1:50).
6. A MINIMUM 2" AGGREGATE SUBBASE (CA-6) SHALL BE PROVIDED. (4" THROUGH COMMERCIAL DRIVEWAYS).
7. AGGREGATE SUBBASE SHALL BE MECHANICALLY COMPACTED.
8. ALL SIDEWALKS SHALL BE PROMPTLY BACKFILLED AND PROTECTED FROM DAMAGE.
9. SIDEWALK CONSTRUCTION SHALL FOLLOW APPLICABLE IDOT STANDARDS.
10. SIDEWALKS SHALL FOLLOW CURRENT ADA GUIDELINES.



City of Naperville
**STANDARD
DETAIL**

SIDEWALK

REVISED: 01/01/2013

SHEET 1 OF 1

PAVEMENT 30

590.30

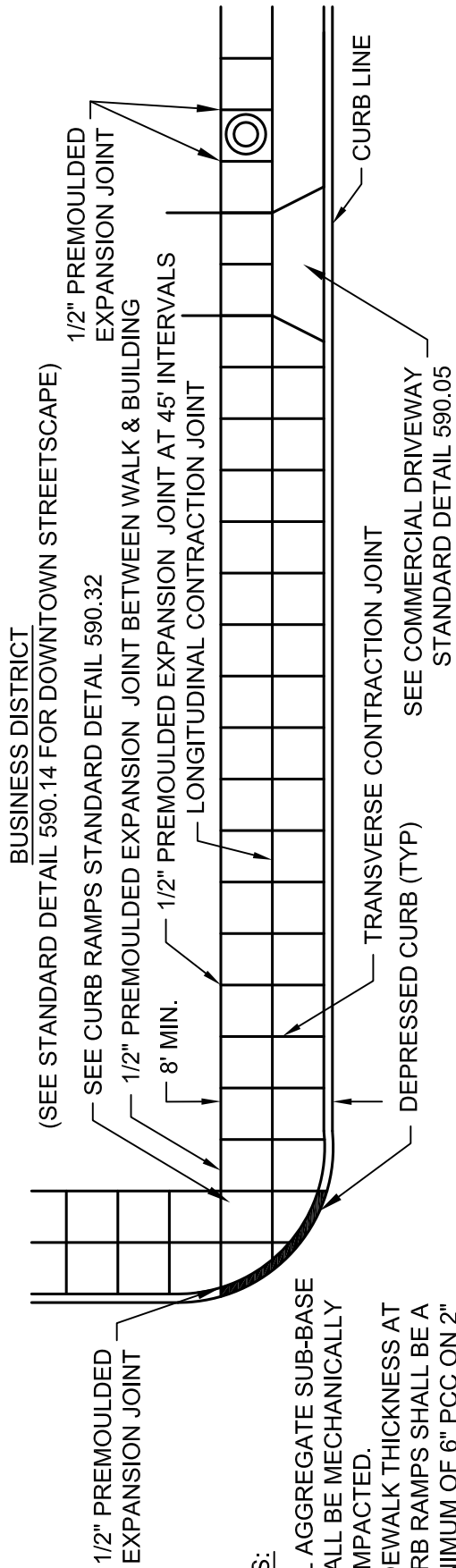

BUSINESS DISTRICT
 (SEE STANDARD DETAIL 590.14 FOR DOWNTOWN STREETSCAPE)
 SEE CURB RAMPS STANDARD DETAIL 590.32
 1/2" PREMOFORMED EXPANSION JOINT BETWEEN WALK & BUILDING
 8' MIN.
 1/2" PREMOFORMED EXPANSION JOINT AT 45° INTERVALS
 LONGITUDINAL CONTRACTION JOINT
 DEPRESSED CURB (TYP)
 TRANSVERSE CONTRACTION JOINT
 SEE COMMERCIAL DRIVEWAY
 STANDARD DETAIL 590.05
 CURB LINE

NOTES:

1. ALL AGGREGATE SUB-BASE SHALL BE MECHANICALLY COMPACTED.
2. SIDEWALK THICKNESS AT CURB RAMPS SHALL BE A MINIMUM OF 6" PCC ON 2" AGGREGATE SUB BASE.
3. SIDEWALK CONSTRUCTION SHALL FOLLOW APPLICABLE IDOT STANDARDS.
4. SIDEWALKS SHALL FOLLOW CURRENT ADA GUIDELINES.

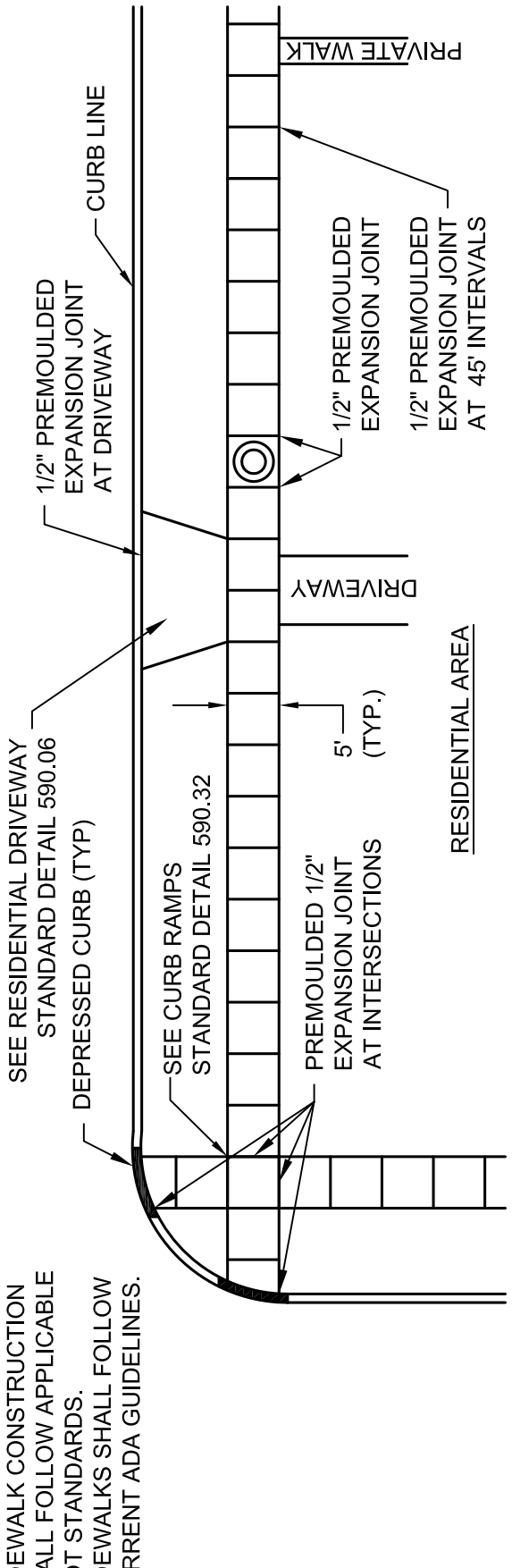

SEE RESIDENTIAL DRIVEWAY
 STANDARD DETAIL 590.06
 DEPRESSED CURB (TYP)
 SEE CURB RAMPS
 STANDARD DETAIL 590.32
 5' (TYP.)
 PREMOFORMED 1/2" EXPANSION JOINT AT INTERSECTIONS
 PRIVATE WALK
 1/2" PREMOFORMED EXPANSION JOINT AT DRIVEWAY
 1/2" PREMOFORMED EXPANSION JOINT AT 45° INTERVALS
 RESIDENTIAL AREA
 CURB LINE



City of Naperville
**STANDARD
 DETAIL**

SIDEWALK CONSTRUCTION

PAVEMENT 31

590.31

REVISED: 01/01/2013

SHEET 1 OF 1

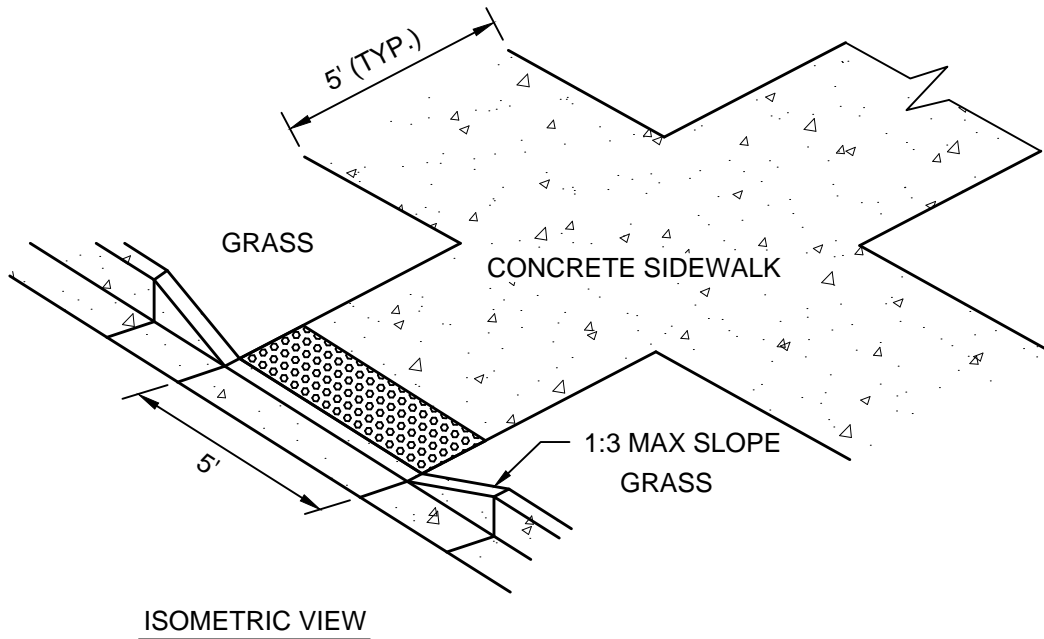

NOTES:

1. ALL AGGREGATE SUB-BASE SHALL BE MECHANICALLY COMPACTED.
2. SIDEWALK THICKNESS AT CURB RAMPS SHALL BE A MINIMUM OF 6" PCC ON 2" AGGREGATE SUB BASE.
3. SIDEWALK CONSTRUCTION SHALL FOLLOW APPLICABLE IDOT STANDARDS.
4. SIDEWALKS SHALL FOLLOW CURRENT ADA GUIDELINES.

APPLICABLE IDOT STANDARD DETAILS (USE LATEST REVISION):

424001-XX	PERPENDICULAR CURB RAMPS FOR SIDEWALKS
424006-XX	DIAGONAL CURB RAMPS FOR SIDEWALKS
424011-XX	CORNER PARALLEL CURB RAMPS FOR SIDEWALKS
424016-XX	MID-BLOCK CURB RAMPS FOR SIDEWALKS
424021-XX	DEPRESSED CORNER FOR SIDEWALKS
424026-XX	ENTRANCE/ALLEY PEDESTRIAN CROSSINGS
424031-XX	MEDIAN PEDESTRIAN CROSSINGS
606001-XX	CONCRETE CURB TYPE B AND COMB CONCRETE CURB AND GUTTER

APPROVED ADA DETECTABLE WARNING TILES:

1. ADA SOLUTIONS - CAST IN PLACE REPLACEABLE
2. ARMOR TILE - CAST IN PLACE
3. DETECTILE - SLIMTEK II
4. TUFTILE - POLYMER WET-SET



City of Naperville
**STANDARD
DETAIL**

CURB RAMPS

REVISED: 08/01/2018

SHEET 1 OF 1

PAVEMENT 32

590.32

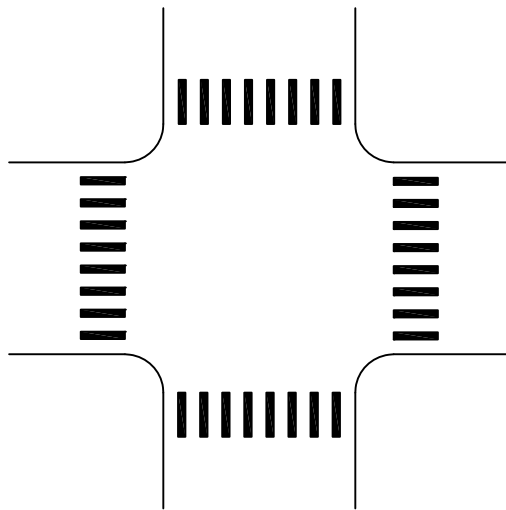

NOTES:

1. SPACING BETWEEN PAVEMENT MARKINGS MAY BE INCREASED TO A MAXIMUM OF 2.5' TO AVOID WHEEL PATHS.

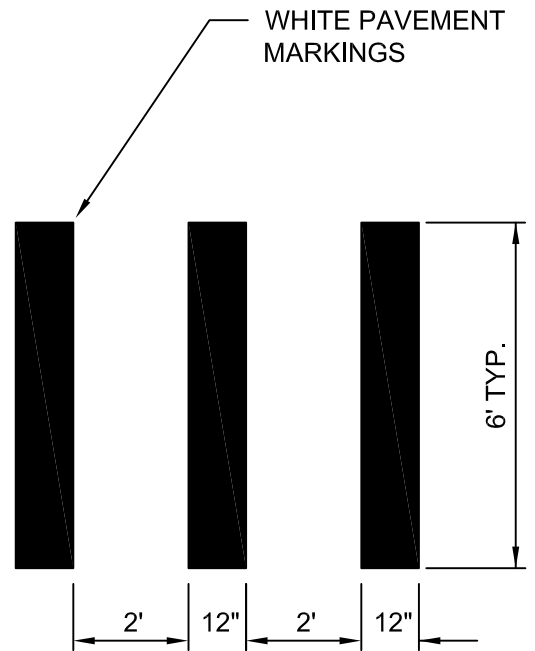

SCHOOL AND PEDESTRIAN

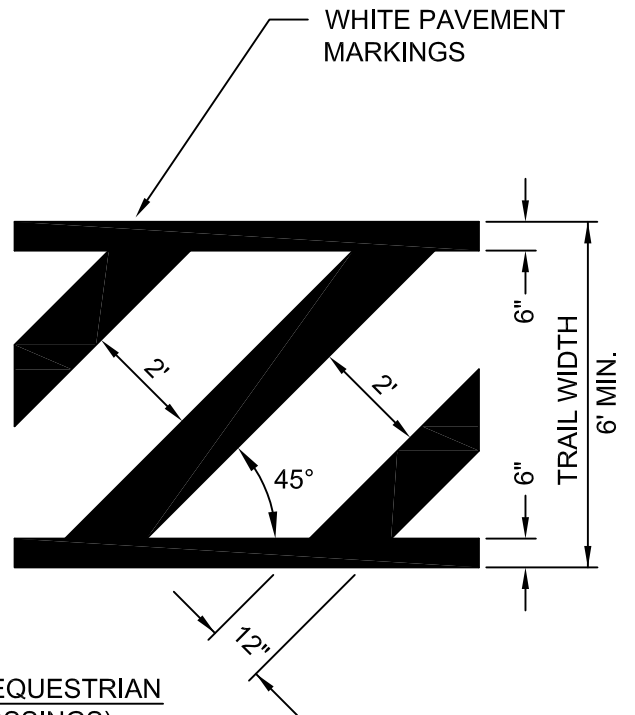
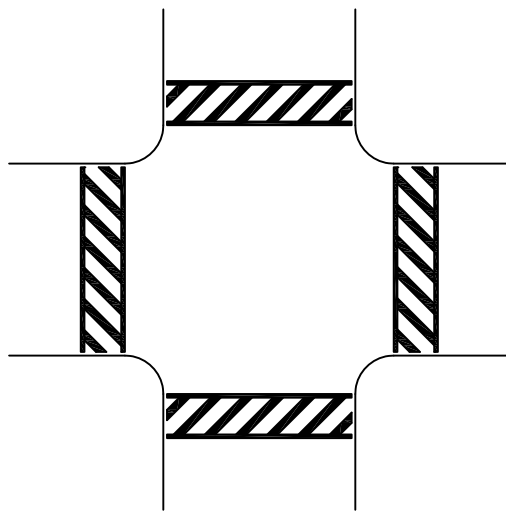

BICYCLE AND EQUESTRIAN
(TRAIL CROSSINGS)



City of Naperville
**STANDARD
DETAIL**

CROSSWALK

REVISED: 06/14/2013

SHEET 1 OF 1

PAVEMENT 33

590.33

NOTE:

CONTRACTOR MUST PROVIDE SHOP DRAWING
DETAIL OF COVERED WALKWAY FOR REVIEW AND
APPROVAL TO THE CHIEF BUILDING OFFICIAL, IF
ALTERNATE MATERIALS FOR WALKWAY ARE
PROPOSED

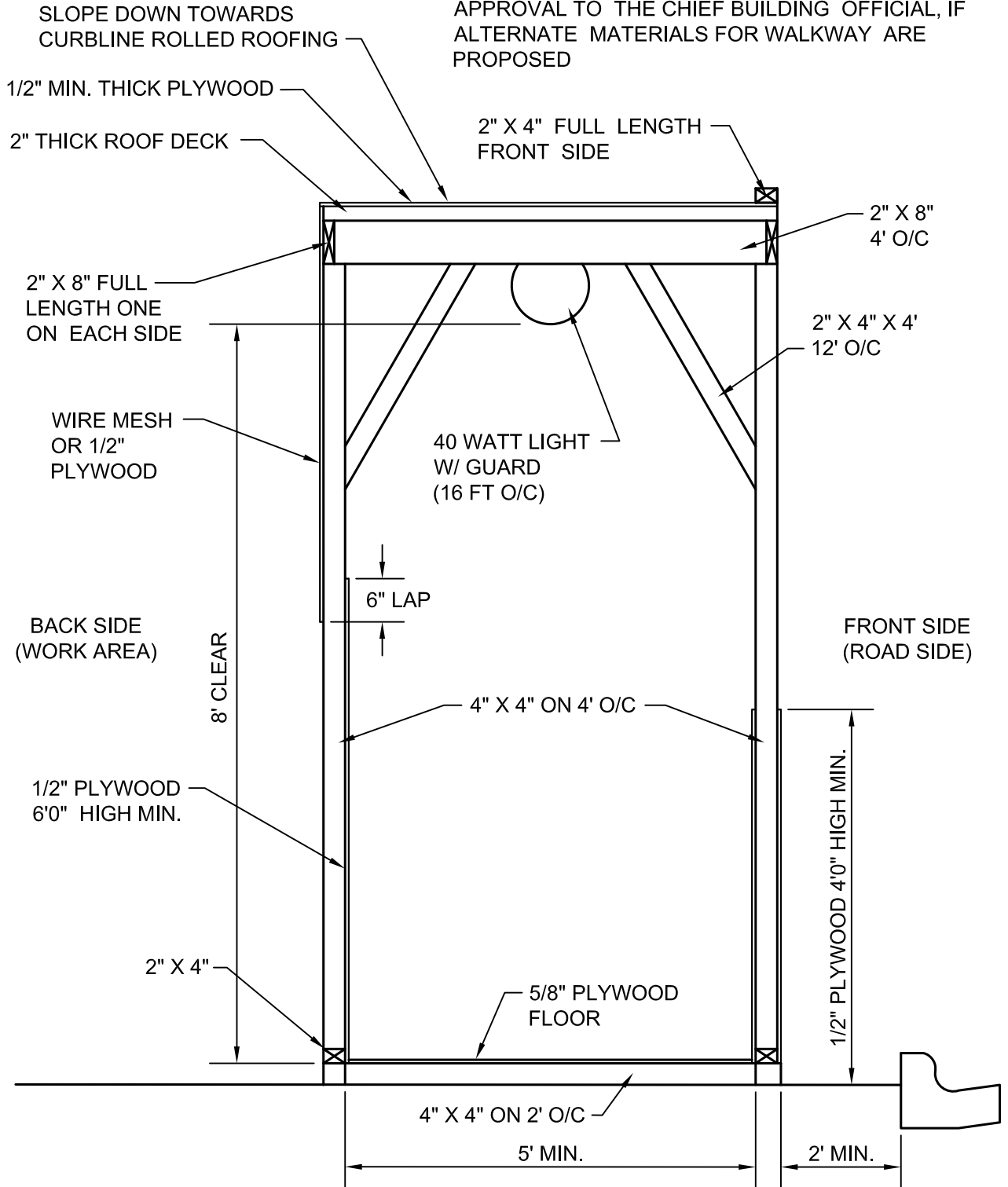

City of Naperville
**STANDARD
DETAIL**

COVERED WALKWAY

REVISED: 01/01/2013

SHEET 1 OF 1

PAVEMENT 34

590.34

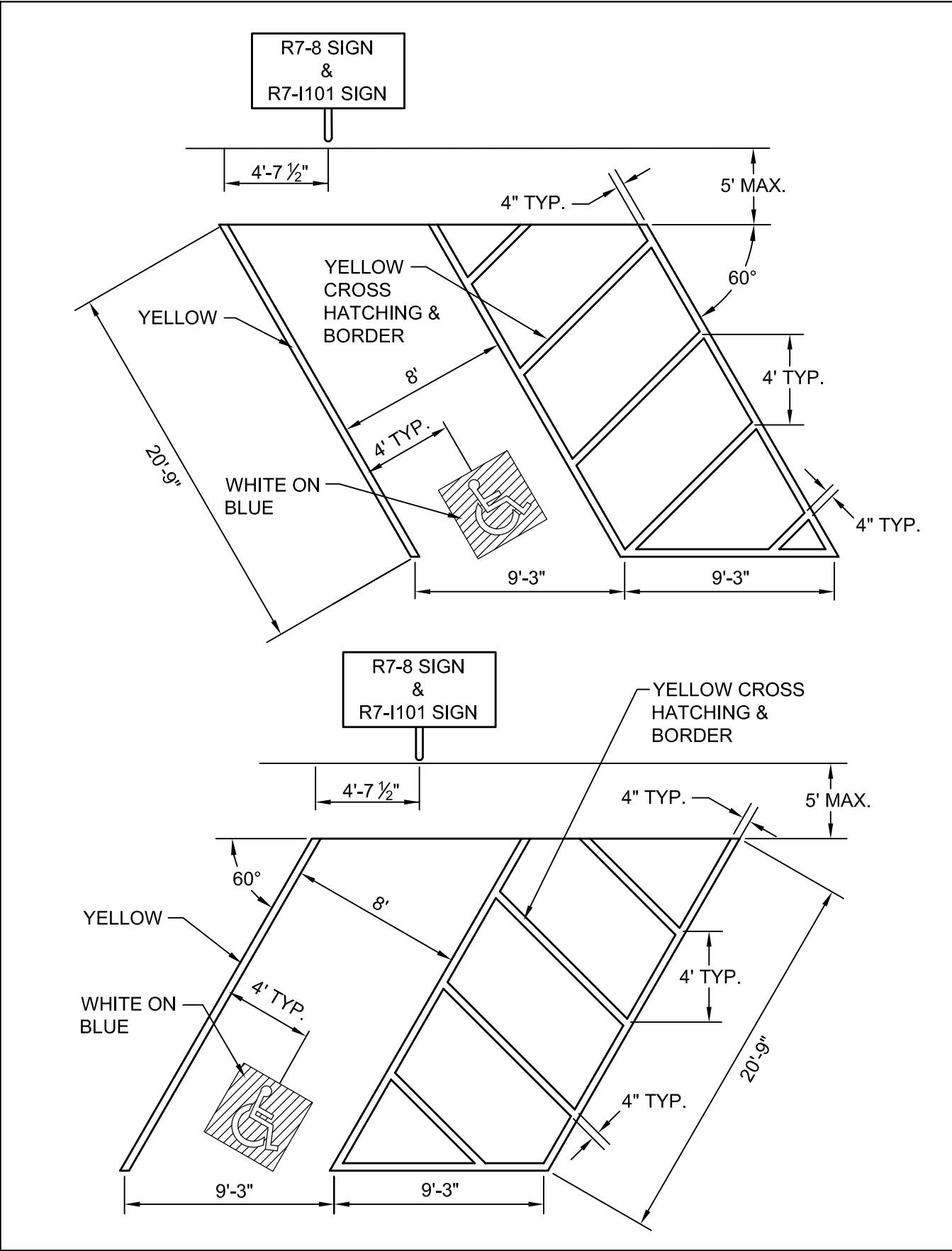

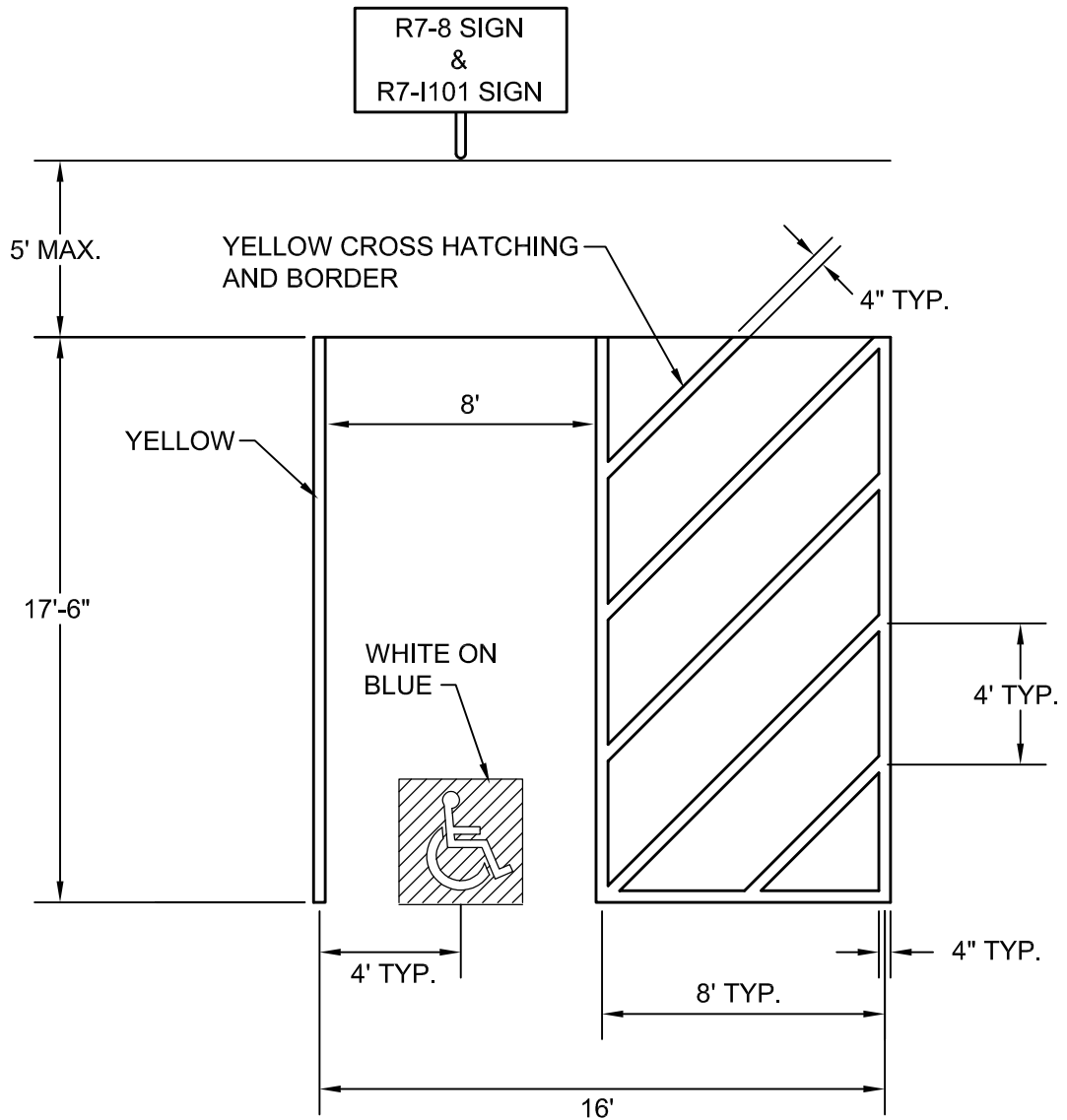

NOTE:

FOR MULTIPLE ACCESSIBLE PARKING SPACES IN A ROW, THE DESIGN ENGINEER HAS THE OPTION OF USING THE ABOVE SHOWN UNIT IN A COMBINATION OF LEFT-HANDED AND RIGHT-HANDED LAYOUTS IF IT PROVIDES FOR BETTER SITE DESIGN.



City of Naperville
**STANDARD
DETAIL**

**ACCESSIBLE PARKING
SPACE MARKINGS**

REVISED: 10/04/2023

SHEET 2 OF 3

PAVEMENT 35

590.35

NOTES FOR ACCESSIBLE PARKING SPACES:

1. EACH PARKING SPACE SHALL BE AT LEAST 16' WIDE, WITH AN 8' WIDE ACCESS AISLE.
2. TWO PARKING SPACES MAY SHARE AN ACCESS AISLE EXCEPT FOR ANGLED PARKING SPACES.
3. PARKING SPACE IDENTIFICATION SIGN WITH INTERNATIONAL SYMBOL OF ACCESSIBILITY (R7-8) SHALL BE MOUNTED ON A PERMANENT POST OR WALL AT THE FRONT CENTER OF THE ACCESSIBLE PARKING SPACE, SET AT A MINIMUM OF 5' ABOVE THE GROUND SURFACE MEASURED TO THE BOTTOM OF THE SIGN AND NO MORE THAN 5' HORIZONTALLY FROM THE FRONT OF A PARKING SPACE.
4. ACCESSIBLE PARKING SIGNS SHALL ALSO EXHIBIT THE WORDS "\$250 FINE" OR THE "\$250 FINE" SIGN (R7-1101) SHALL BE PLACED BENEATH THE ACCESSIBLE PARKING SIGN (R7-8).
5. PARKING SPACES DESIGNED FOR PERSONS WITH DISABILITIES AND ACCESSIBLE PASSENGER LOADING ZONES THAT SERVE A PARTICULAR BUILDING, SHALL BE LOCATED ON THE SHORTEST POSSIBLE ACCESSIBLE CIRCULATION ROUTE TO AN ACCESSIBLE ENTRANCE OF THE BUILDING.
6. IN SEPARATE PARKING STRUCTURES OR LOTS THAT DO NOT SERVE A PARTICULAR BUILDING, PARKING SPACES FOR PERSONS WITH DISABILITIES SHALL BE LOCATED ON THE SHORTEST POSSIBLE CIRCULATION ROUTE TO AN ACCESSIBLE PEDESTRIAN ENTRANCE OF THE PARKING FACILITY.



ACCESSIBLE PARKING SIGN (R7-8)



"\$250 FINE" SIGN (R7-1101)



VAN ACCESSIBLE SIGN (OPTIONAL)
18" x 9"
2" SERIES D LETTERS

# OF ACCESSIBLE SPACES REQUIRED PER # OF OFF STREET PARKING	
TOTAL OFF STREET PARKING SPACES REQUIRED	REQUIRED MINIMUM NUMBER OF ACCESSIBLE PARKING SPACES
1 TO 25	1
26 TO 50	2
51 TO 75	3
76 TO 100	4
101 TO 150	5
151 TO 200	6
201 TO 300	7
301 TO 400	8
401 TO 500	9
501 TO 1000	2% OF TOTAL NUMBER
OVER 1000	20 PLUS 1 FOR EACH 100 OVER 1000

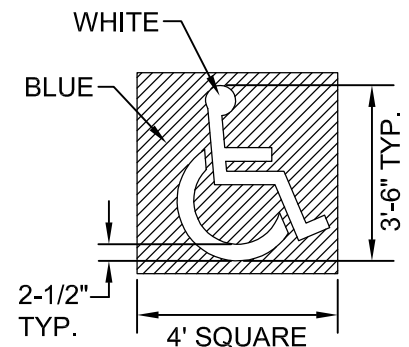

ACCESSIBLE SYMBOL LINES SHALL BE WHITE.



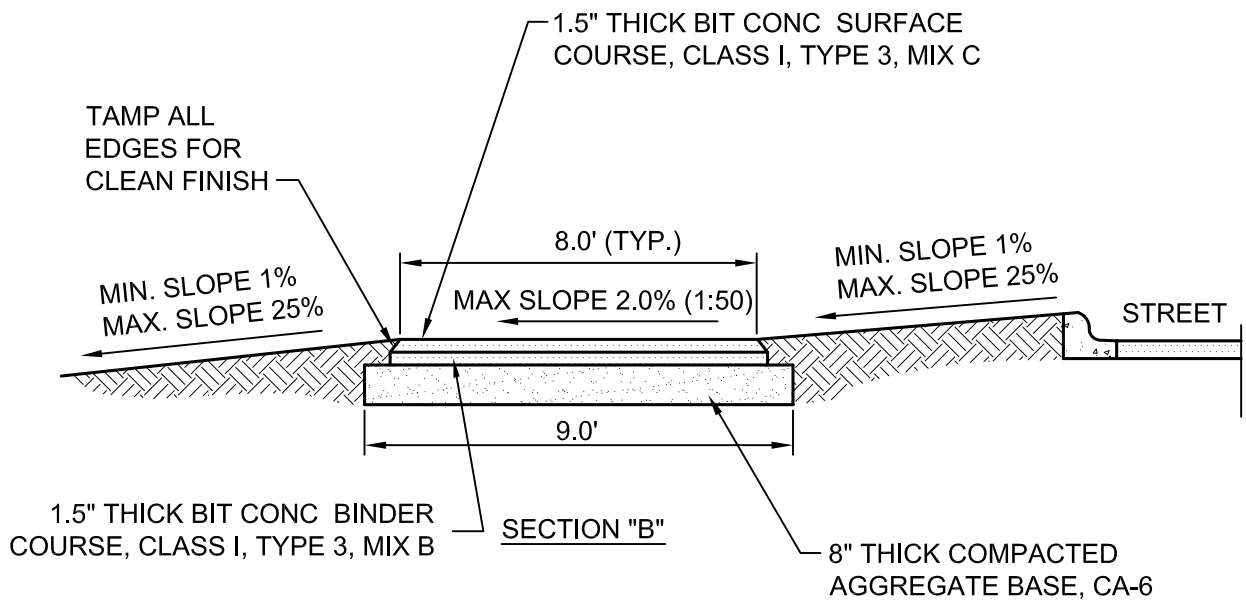
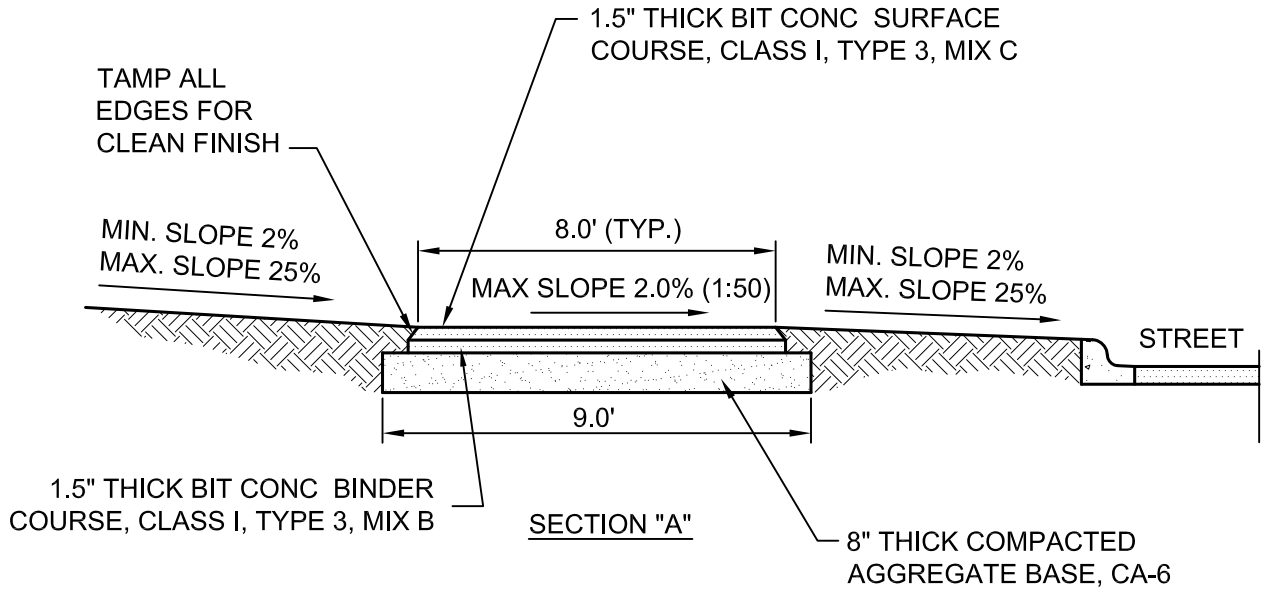

NOTES:

1. ALL AGGREGATE SUB-BASE SHALL BE MECHANICALLY COMPACTED.
2. SIDEWALK CONSTRUCTION SHALL FOLLOW APPLICABLE IDOT STANDARDS.
3. SIDEWALKS SHALL FOLLOW CURRENT ADA GUIDELINES.



City of Naperville
**STANDARD
DETAIL**

MULTI-USE TRAIL

REVISED: 01/01/2013

SHEET 1 OF 1

PAVEMENT 36

590.36